

DATA SHEET

SAA7110; SAA7110A **One Chip Front-end 1 (OCF1)**

Product specification
File under Integrated Circuits, IC22

1995 Oct 18

One Chip Front-end 1 (OCF1)

SAA7110; SAA7110A

CONTENTS			
1	FEATURES	23.1	CODE 0 STARTUP and STANDARD Procedure
2	APPLICATIONS	23.2	MODE 0 Source Select Procedure
3	GENERAL DESCRIPTION	23.3	MODE 1 Source Select Procedure
4	QUICK REFERENCE DATA	23.4	MODE 2 Source Select Procedure
5	ORDERING INFORMATION	23.5	MODE 3 Source Select Procedure
6	SYSTEM VIEW	23.6	MODE 4 Source Select Procedure
7	BLOCK DIAGRAM	23.7	MODE 5 Source Select Procedure
8	PINNING	23.8	MODE 6 Source Select Procedure
9	FUNCTIONAL DESCRIPTION	23.9	MODE 7 Source Select Procedure
9.1	Analog input processing (see Fig.5)	23.10	MODE 8 Source Select Procedure
9.2	Analog control circuits	24	PACKAGE OUTLINE
9.3	Chrominance processing (see Fig.6)	25	SOLDERING
9.4	Luminance processing (see Fig.7)	25.1	Introduction
9.5	YUV-bus (digital outputs)	25.2	Reflow soldering
9.6	Synchronization (see Fig.7)	25.3	Wave soldering
9.7	Clock generation circuit	25.4	Repairing soldered joints
9.8	Power-on reset	26	DEFINITIONS
9.9	RTCO output	27	LIFE SUPPORT APPLICATIONS
10	GAIN CHARTS	28	PURCHASE OF PHILIPS I ² C COMPONENTS
11	LIMITING VALUES		
12	CHARACTERISTICS		
13	TIMING		
14	OUTPUT FORMATS		
15	CLOCK SYSTEM		
15.1	Clock generation circuit		
15.2	Power-on control		
16	I ² C-BUS DESCRIPTION		
16.1	I ² C-bus format		
16.2	I ² C-bus receiver/transmitter tables		
16.3	I ² C-bus detail		
16.4	I ² C-bus detail (continued)		
17	SOURCE SELECTION MANAGEMENT		
18	ANTI-ALIAS FILTER GRAPHS		
19	CORING FUNCTION		
19.1	Coring function adjustment by subaddress 06H to affect band filter output adjustment		
20	LUMINANCE FILTER GRAPHS		
21	I ² C-BUS START SET-UP		
21.1	Remarks to Table 66		
22	APPLICATION INFORMATION		
23	START-UP, SOURCE SELECT AND STANDARD DETECTION FLOW EXAMPLE		



One Chip Front-end 1 (OCF1)

SAA7110; SAA7110A

1 FEATURES

- Six analog inputs (6 × CVBS or 3 × Y/C or combinations)
- Three analog processing channels
- Three built-in analog anti-aliasing filters
- Analog signal adding of two channels
- Two 8-bit video CMOS analog-to-digital converters
- Fully programmable static gain for the main channels or automatic gain control for the selected CVBS/Y channel
- Selectable white peak control signal
- Luminance and chrominance signal processing for PAL B/G, NTSC M and SECAM
- Full range HUE control
- Automatic detection of 50/60 Hz field frequency, and automatic switching between standards PAL and NTSC, SECAM forceable
- Horizontal and vertical sync detection for all standards
- Cross-colour reduction by chrominance comb filtering for NTSC or special cross-colour cancellation for SECAM
- UV signal delay lines for PAL to correct chrominance phase errors
- The YUV-bus supports a data rate of:
 - $780 \times f_h = 12.2727$ MHz for 60 Hz (NTSC)
 - $944 \times f_h = 14.75$ MHz for 50 Hz (PAL/SECAM)
- Square pixel format with 768/640 active samples per line on the YUV-bus
- CCIR 601 level compatible
- 4 : 2 : 2 and 4 : 1 : 1 YUV output formats in 8-bit resolution
- User programmable luminance peaking for aperture correction
- Compatible with memory-based features (line-locked clock, square pixel)

- Requires only one crystal (26.8 MHz) for all standards
- Real time status information output (RTCO)
- Brightness Contrast Saturation (BCS) control for the YUV-bus
- Negation of picture possible
- One user programmable general purpose switch on an output pin
- Switchable between on-chip Clock Generation Circuit (CGC) and external CGC (SAA7197)
- Power-on control
- I²C-bus controlled.

2 APPLICATIONS

- Desktop video
- Multimedia
- Digital television
- Image processing
- Video phone
- Video picture grabbing.

3 GENERAL DESCRIPTION

The one chip front-end SAA7110; SAA7110A is a digital multistandard colour decoder (OCF1) on the basis of the DIG-TV2 system with two integrated Analog-to-Digital Converters (ADCs), a Clock Generation Circuit (CGC) and Brightness Contrast Saturation (BCS) control.

The CMOS circuit SAA7110; SAA7110A, analog front-end and digital video decoder, is a highly integrated circuit for desktop video applications. The decoder is based on the principle of line-locked clock decoding. It operates square-pixel frequencies to achieve correct aspect ratio. Monitor controls are provided to ensure best display. The circuit is I²C-bus controlled.

4 QUICK REFERENCE DATA

SYMBOL	PARAMETER	MIN.	MAX.	UNIT
V _{DDA}	analog supply voltage	4.75	5.25	V
V _{DDD}	digital supply voltage	4.5	5.5	V
T _{amb}	operating ambient temperature	0	70	°C

One Chip Front-end 1 (OCF1)

SAA7110; SAA7110A

5 ORDERING INFORMATION

TYPE NUMBER	PACKAGE		
	NAME	DESCRIPTION	VERSION
SAA7110	PLCC68	plastic leaded chip carrier; 68 leads	SOT188-2
SAA7110A	PLCC68	plastic leaded chip carrier; 68 leads	SOT188-2

6 SYSTEM VIEW

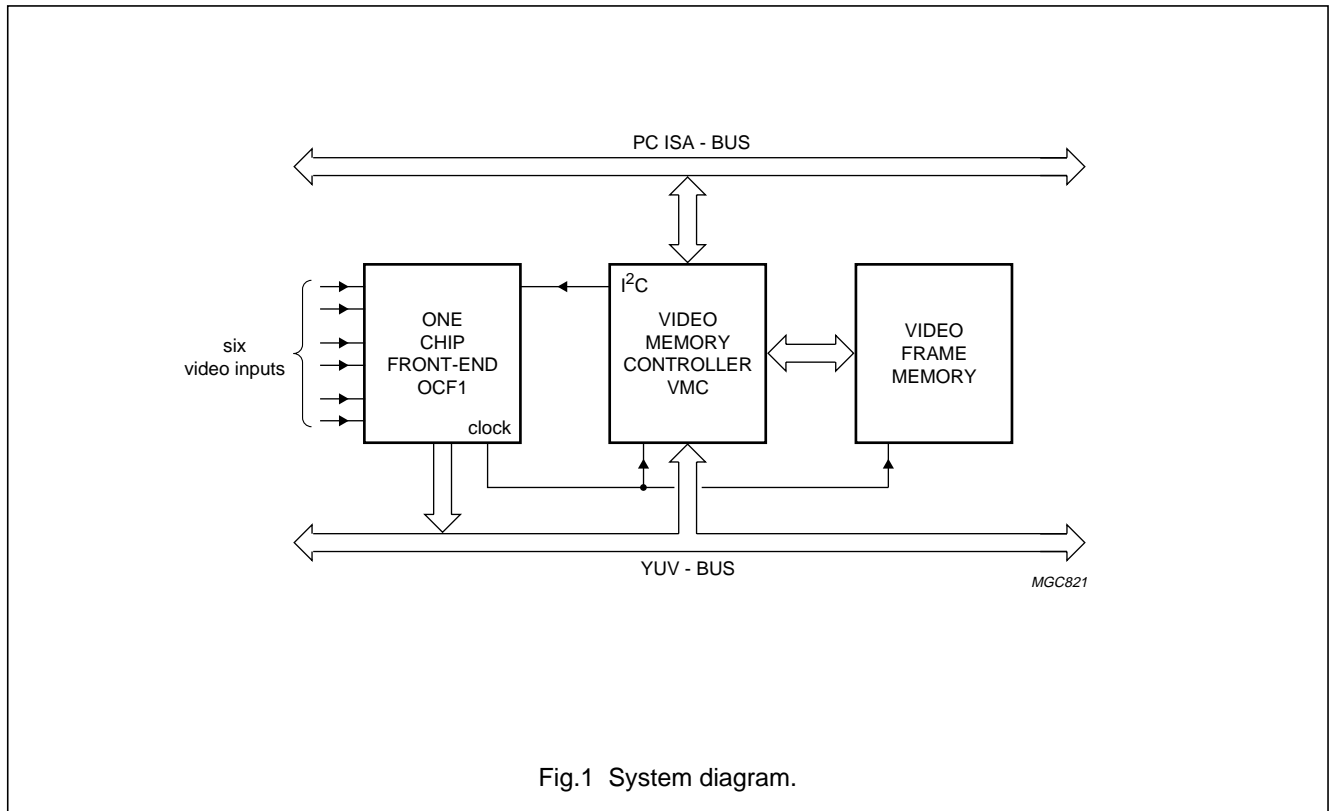

Fig.1 System diagram.

One Chip Front-end 1 (OCF1)

SAA7110; SAA7110A

7 BLOCK DIAGRAM

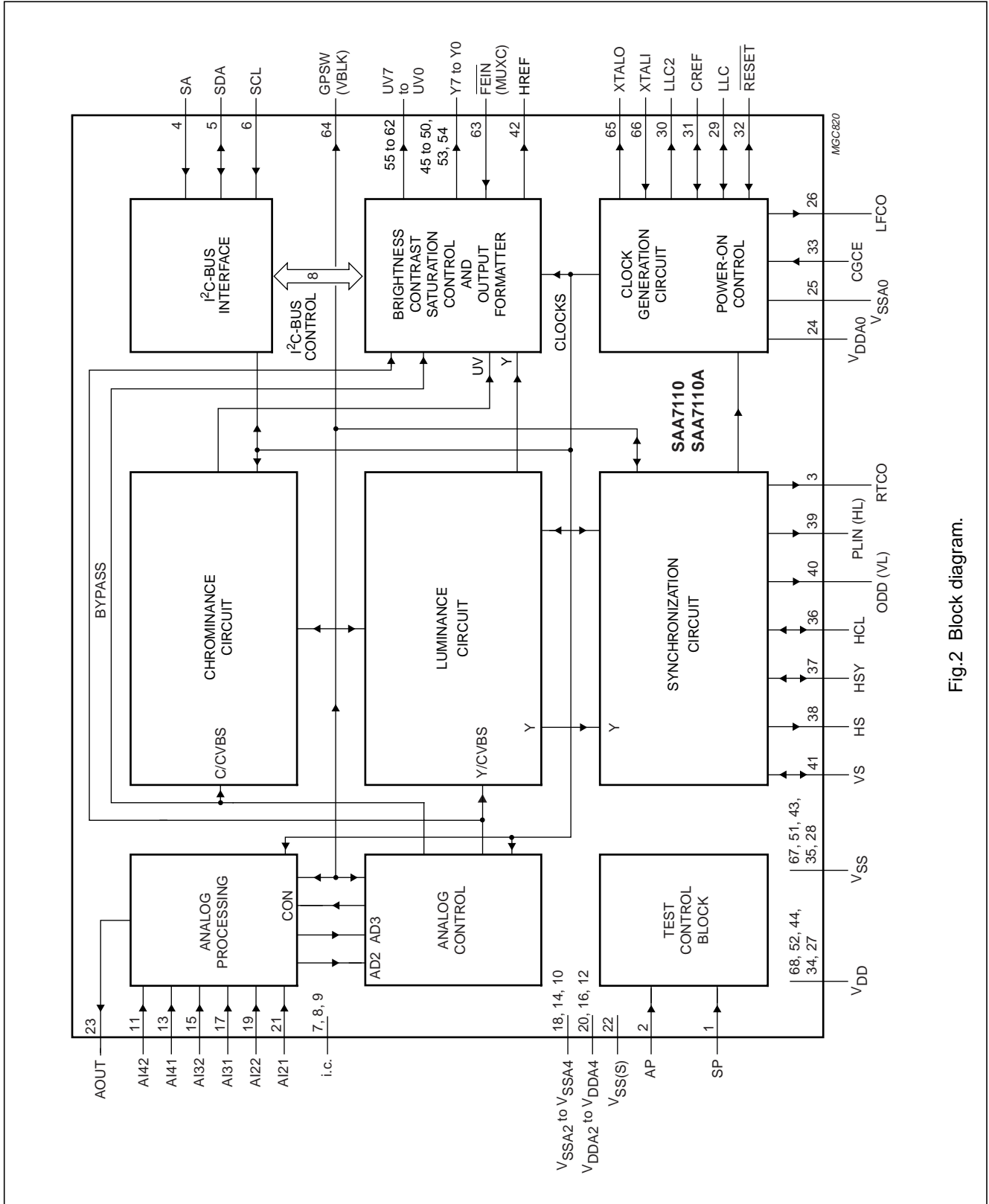

Fig.2 Block diagram.

One Chip Front-end 1 (OCF1)

SAA7110; SAA7110A

8 PINNING

SYMBOL	PIN	DESCRIPTION
SP	1	test pin input; (shift pin) connect to ground for normal operation
AP	2	test pin input; (action pin) connect to ground for normal operation
RTCO	3	Real Time Control Output. This pin is used to fit serially the increments of the HPLL and FSC-PLL and information of the PAL or SECAM sequence.
SA	4	I ² C-bus slave address select input. LOW: slave address = 9CH for write, 9DH for read; HIGH = 9DH for write, 9FH for read.
SDA	5	I ² C-bus serial data input/output
SCL	6	I ² C-bus serial clock input
i.c.	7	reserved pin; do not connect
i.c.	8	reserved pin; do not connect
i.c.	9	reserved pin; do not connect
V _{SSA4}	10	ground for analog input 4
AI42	11	analog input 42
V _{DDA4}	12	supply voltage (+5 V) for analog input 4
AI41	13	analog input 41
V _{SSA3}	14	ground for analog input 3
AI32	15	analog input 32
V _{DDA3}	16	supply voltage (+5 V) for analog input 3
AI31	17	analog input 31
V _{SSA2}	18	ground for analog input 2
AI22	19	analog input 22
V _{DDA2}	20	supply voltage (+5 V) for analog input 2
AI21	21	analog input 21
V _{SS(S)}	22	substrate ground
AOUT	23	analog test output; do not connect
V _{DDA0}	24	supply voltage (+5 V) for internal CGC (Clock Generation Circuit)
V _{SSA0}	25	ground for internal CGC
LFCO	26	Line Frequency Control output; this is the analog clock control signal driving the external CGC. The frequency is a multiple of the actual line frequency (nominally 7.375/6.13636 MHz). The signal has a triangular form with 4-bit accuracy.
V _{DD}	27	supply voltage (+5 V)
V _{SS}	28	ground
LLC	29	Line-Locked Clock input/output (CGCE = 1, output; CGCE = 0, input). This is the system clock, its frequency is $1888 \times f_h$ for 50 Hz/625 lines per field systems and $1560 \times f_h$ for 60 Hz/525 lines per field systems; or variable input clock up to 32 MHz in input mode.
LLC2	30	Line-Locked Clock $\frac{1}{2}$ output; $f_{LLC2} = 0.5 \times f_{LLC}$ (CGCE = 1, output; CGCE = 0, high impedance).
CREF	31	Clock reference input/output (CGCE = 1, output; CGCE = 0, input). This is a clock qualifier signal distributed by the internal or an external clock generator circuit (CGC). Using CREF all interfaces on the YUV-bus are able to generate a bus timing with identical phase.

One Chip Front-end 1 (OCF1)

SAA7110; SAA7110A

SYMBOL	PIN	DESCRIPTION
RESET	32	Reset active LOW input/output (CGCE = 1, output; CGCE = 0, input); sets the device into a defined state. All data outputs are in high impedance state. The I ² C-bus is reset (waiting for START condition). Using the external CGC, the LOW period must be maintained for at least 30 LLC clock cycles.
CGCE	33	CGC Enable active HIGH input (CGCE = 1, on-chip CGC active; CGCE = 0, external CGC mode, use SAA7197).
V _{DD}	34	supply voltage (+5 V)
V _{SS}	35	ground
HCL	36	Horizontal Clamping input/output pulse (programmable via I ² C-bus bit PULIO: PULIO = 1, output; PULIO = 0, input). This signal is used to indicate the black level clamping period for the analog input interface. The beginning and end of its HIGH period (only in the output mode) can be programmed via the I ² C-bus registers 03H, 04H in 50 Hz mode and registers 16H, 17H in 60 Hz mode, active HIGH.
HSY	37	Horizontal Synchronization input/output indicator (programmable via I ² C-bus bit PULIO: PULIO = 1, output; PULIO = 0, input). This signal is fed to the analog interface. The beginning and end of its HIGH period (only in the output mode) can be programmed via the I ² C-bus registers 01H, 02H in 50 Hz mode and registers 14H, 15H in 60 Hz mode, active HIGH.
HS	38	Horizontal Synchronization output (programmable; the HIGH period is 128 LLC clock cycles). The position of the positive slope is programmable in 8 LLC increments over a complete line (64 μ s) via the I ² C-bus register 05H in 50 Hz mode or register 18H in 60 Hz mode.
PLIN (HL)	39	PAL Identifier Not output; marks for demodulated PAL signals the inverted line (PLIN = LOW) and a non-inverted line (PLIN = HIGH) and for demodulated SECAM the DR line (PLIN = LOW) and the DB line (PLIN = HIGH). Select PLIN function via I ² C-bus bit RTSE = 0. (H-PLL locked output; a HIGH state indicates that the internal PLL has locked. Select HL function via I ² C-bus bit RTSE = 1).
ODD (VL)	40	ODD/EVEN field identification output; a HIGH state indicates the odd field. Select ODD function via I ² C-bus bit RTSE = 0. (Vertical Locked output; a HIGH state indicates that the internal Vertical Noise Limiter (VNL) is in a locked state. Select VL function via I ² C-bus bit RTSE = 1).
VS	41	Vertical Synchronization input/output (programmable via I ² C-bus bit OEHV: OEHV = 1, output; OEHV = 0, input). This signal indicates the vertical synchronization with respect to the YUV output. The high period of this signal is approximately six lines if the VNL function is active. The positive slope contains the phase information for a deflection controller, for example the TDA9150. In input mode this signal is used to synchronize the vertical gain and clamp blanking stage, active HIGH.
HREF	42	Horizontal Reference output; this signal is used to indicate data on the digital YUV-bus. The positive slope marks the beginning of a new active line. The HIGH period of HREF is either 768 Y samples or 640 Y samples long depending on the detected field frequency (50/60 Hz mode). HREF is used to synchronize data multiplexer/demultiplexers. HREF is also present during the vertical blanking interval.
V _{SS}	43	ground
V _{DD}	44	supply voltage (+5 V)

One Chip Front-end 1 (OCF1)

SAA7110; SAA7110A

SYMBOL	PIN	DESCRIPTION
Y7	45	Upper 6 bits of the 8-bit luminance (Y) digital output. As part of the digital YUV-bus (data rate LLC/2), or A/D2(3) output (data rate LLC/2) selectable via I ² C-bus bit SQPB = 1.
Y6	46	
Y5	47	
Y4	48	
Y3	49	
Y2	50	
V _{SS}	51	ground
V _{DD}	52	supply voltage (+5 V)
Y1	53	Lower 2 bits of the 8-bit luminance (Y) digital output. As part of the digital YUV-bus (data rate LLC/2), or A/D2(3) output (data rate LLC/2) selectable via I ² C-bus bit SQPB = 1.
Y0	54	
UV7	55	8-bit digital UV (colour difference) output; multiplexed colour difference signal for U and V component of demodulated CVBS or chrominance signal. The format and multiplexing scheme can be selected via I ² C-bus control. These signals are part of the digital YUV-bus (data rate LLC/2), or A/D3(2) output (data rate LLC/2) selectable via I ² C-bus bit SQPB = 1.
UV6	56	
UV5	57	
UV4	58	
UV3	59	
UV2	60	
UV1	61	
UV0	62	
FEIN (MUXC)	63	Fast Enable input (active LOW); this signal is used to control fast switching on the digital YUV-bus. A high at this input forces the IC to set its Y and UV outputs to the high impedance state. To use this function set I ² C-bus bits MS24 and MS34 and MUYC to LOW. (Multiplex Components input; control signal for the analog multiplexers for fast switching between locked Y/C signals or locked CVBS signals. FEIN automatically fixed to LOW (digital YUV-bus enabled), if one of the three MUXC functions are selected (MS24 or MS34 or MUYC = HIGH).
GPSW (VBLK)	64	General Purpose Switch output; the state of this signal is programmable via I ² C-bus register 0Dh, bit 1. Select GPSW function via I ² C-bus bit VBLKA = 0. (Vertical Blank test output; select VBLK via I ² C-bus bit VBLKA = 1).
XTALO	65	Crystal oscillator output (to 26.8 MHz crystal); not used if TTL clock is used.
XTALI	66	Crystal oscillator input (from 26.8 MHz crystal) or connection of external oscillator with TTL compatible square wave clock signal.
V _{SS}	67	ground
V _{DD}	68	supply voltage (+5 V)

One Chip Front-end 1 (OCF1)

SAA7110; SAA7110A

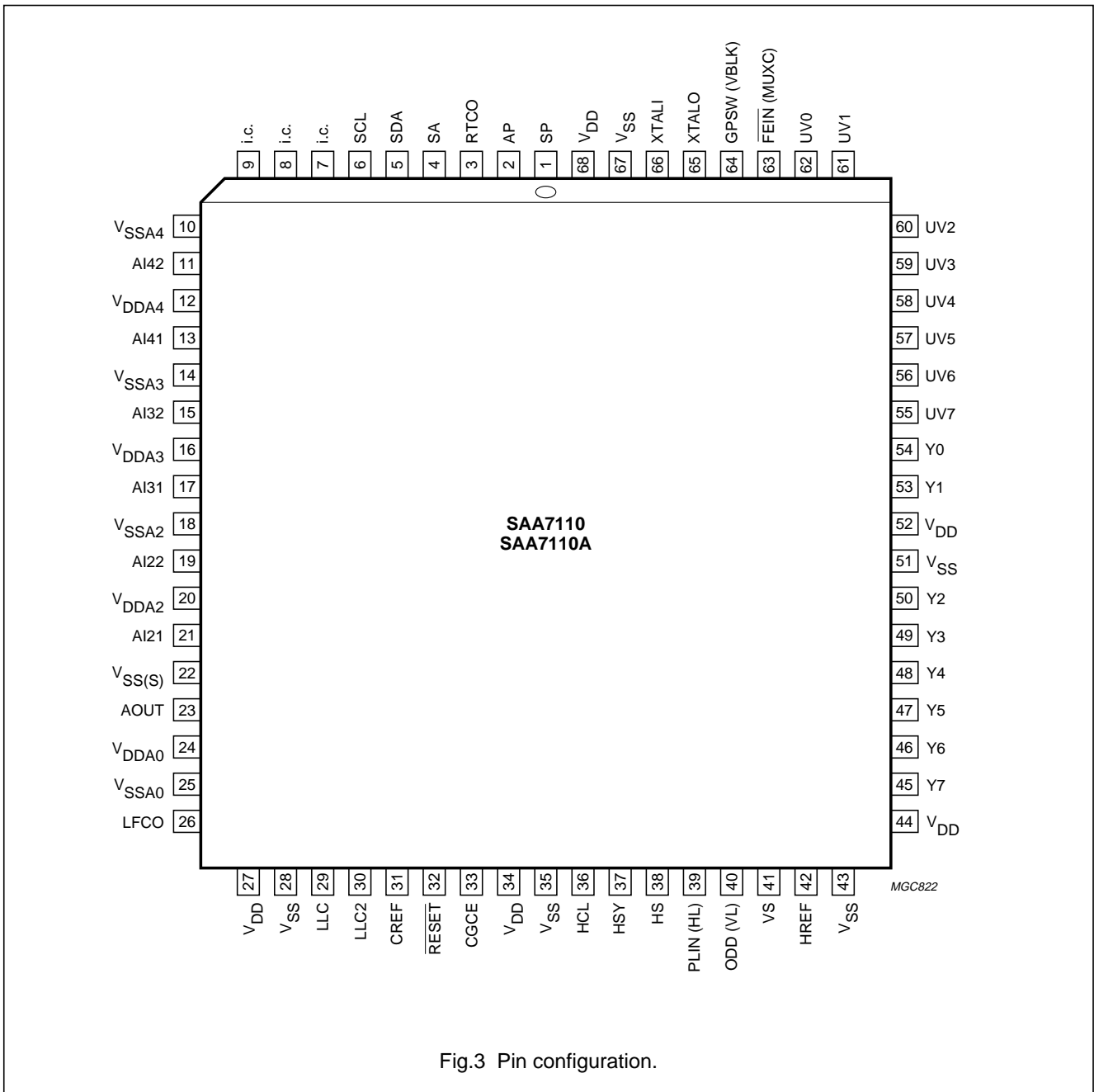

One Chip Front-end 1 (OCF1)

SAA7110; SAA7110A

9 FUNCTIONAL DESCRIPTION

9.1 Analog input processing (see Fig.5)

The SAA7110; SAA7110A offers six analog signal inputs, two analog main channels with clamping circuit, analog amplifier, anti-alias filter and video CMOS ADC. A third analog channel also with clamping circuit, analog amplifier and anti-alias filter can be added or switched to both main channels directly before the ADCs.

9.2 Analog control circuits

The clamping control circuit controls the correct clamping of the analog input signals. The coupling capacitor is also used to store and filter the clamping voltage. The normal digital clamping level for luminance or CVBS signals is 64 and for chrominance signals is 128.

The gain control circuits generate via I²C-bus the static gain levels for the three analog amplifiers or controls one of these amplifiers automatically via a built-in Automatic Gain Control (AGC). The AGC is used to amplify a CVBS or Y signal to the required signal amplitude, matched to the ADCs input voltage range.

The anti-alias filters are adapted to the clock frequency. The vertical blanking control circuit generates an I²C-bus programmable vertical blanking pulse. During the vertical blanking time gain and clamping control are frozen.

The fast switch control circuit is used for special applications.

9.2.1 CLAMPING

The coupling capacitor is used as clamp capacitance for each input. An internal digital clamp comparator generates the information concerning clamp-up or clamp-down. The clamping levels for the two ADC channels are adjustable over the 8-bit range (1 to 254). Clamping time in normal use is set with the HCL pulse at the back porch of the video signal. The clamping pulse HCL is user adjustable.

9.2.2 GAIN CONTROL (see Fig.4)

The luminance AGC can be used for every channel where luminance or CVBS is being received. AGC active time is the sync tip of the video signal. The sync tip pulse HSY is user adjustable. The AGC can be switched off and the gain for the three main input channels can be adjusted independently. Signal (white) peak control limits the gain at signal overshoots. The flow charts (see Figs 8 and 9) show more details of the AGC. The influence of supply voltage variation within the specified range is automatically eliminated by clamp and automatic gain control.

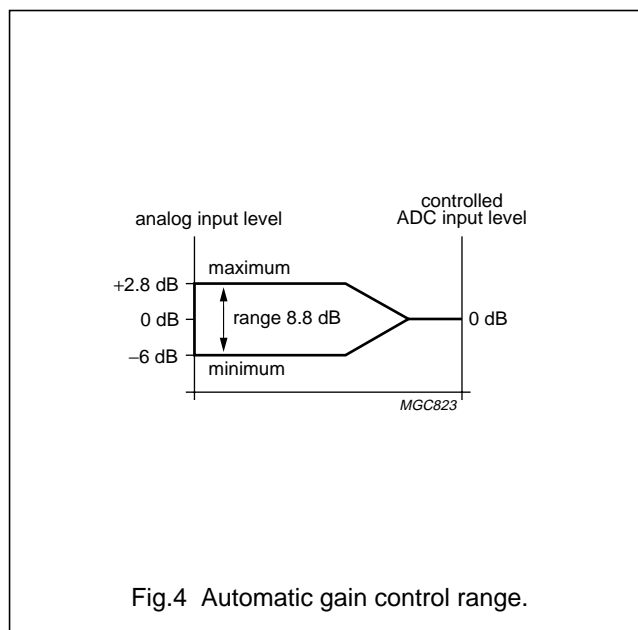

Fig.4 Automatic gain control range.

9.3 Chrominance processing (see Fig.6)

The 8-bit chrominance signal passes the input interface, the chrominance bandpass filter to eliminate DC components, and is finally fed to the multiplication inputs of a quadrature demodulator, where two subcarrier signals from the local oscillator DTO1 with 90 degrees phase shift are applied. The frequency is dependent on the present colour standard.

The multiplier operates as a quadrature demodulator for all PAL and NTSC signals; it operates as a frequency down mixer for SECAM signals.

The two multiplier output signals are converted to a serial UV data stream and applied to two low-pass filter stages, then to a gain controlled amplifier. A final multiplexed low-pass filter achieves, together with the preceding stages, the required bandwidth performance.

The PAL and NTSC originated signals are applied to a comb filter.

The signal originated from SECAM is fed through a Cloche filter (0 Hz centre frequency), a phase demodulator and a differentiator to obtain frequency demodulated colour difference signals. The SECAM signal is fed after de-emphasis to a cross-over switch, to provide both the serial transmitted colour difference signals. These signals are fed to the BCS control and finally to the output formatter stage and to the output interface.

One Chip Front-end 1 (OCF1)

SAA7110; SAA7110A

9.4 Luminance processing (see Fig.7)

The 8-bit luminance signal, a digital CVBS format or a luminance format (S-VHS, HI8), is fed through a switchable prefilter. High frequency components are emphasized to compensate for loss. The following chrominance trap filter ($f_c = 4.43$ or 3.58 MHz centre frequency selectable) eliminates most of the colour carrier signal, therefore, it must be bypassed for S-Video (S-VHS, HI8) signals.

The high frequency components of the luminance signal can be peaked (control for sharpness improvement via I²C-bus) in two bandpass filters with selectable transfer characteristics.

A coring circuit with selectable characteristics improves the signal once more. This signal is then added to the original (unpeaked) signal. A switchable amplifier achieves common DC amplification, because the DC gains are different in both chrominance trap modes.

The improved luminance signal is fed via the variable delay to the BCS control and the output interface.

9.5 YUV-bus (digital outputs)

The 16-bit YUV-bus transfers digital data from the output interfaces to a feature box, or a field memory, a digital colour space converter (SAA 7192 DCSC) or a video enhancement and digital-to-analog processor (SAA7165 VEDA2). The outputs are controlled by an output enable chain (\overline{FEIN} on pin 63).

The YUV data rate equals LLC2. Timing is achieved by marking each second positive rising edge of the clock LLC in conjunction with CREF (clock reference).

The output signals Y7 to Y0 are the bits of the digital luminance signal. The output signals UV7 to UV0 are the bits of multiplexed colour difference signals (B-Y) and (R-Y). The frame in the format tables is the time, required to transfer a full set of samples. In the event of 4 : 2 : 2 format two luminance samples are transmitted in comparison to one U and one V sample within the frame. The time frames are controlled by the HREF signal.

Fast enable is achieved by setting input \overline{FEIN} to LOW. The signal is used to control fast switching on the digital YUV-bus. HIGH on this pin forces the Y and UV outputs to a high-impedance state.

9.6 Synchronization (see Fig.7)

The pre-filtered luminance signal is fed to the synchronization stage. Its bandwidth is reduced to 1 MHz in a low-pass filter.

The synchronization pulses are sliced and fed to the phase detectors where they are compared with the sub-divided clock frequency. The resulting output signal is applied to the loop filter to accumulate all phase deviations.

Adjustable output signals HCL and HSY are generated in accordance with analog front end requirements. The output signals HS, VS, and PLIN are locked to the timing reference, guaranteed between the input signal and the HREF signal, as further improvements to the circuit may change the total processing delay. It is therefore not recommended to use them for applications which require absolute timing accuracy to the input signals. The loop filter signal drives an oscillator to generate the line frequency control signal LFCO.

9.7 Clock generation circuit

The internal CGC generates all clock signals required for the one chip front-end. The output signal LFCO is a digital-to-analog converted signal provided by the horizontal PLL. It is the multiple of the line frequency ($7.38 \text{ MHz} = 472 \times f_h$ in 50 Hz systems and $6.14 \text{ MHz} = 360 \times f_h$ in 60 Hz systems). Internally the LFCO signal is multiplied by a factor of 2 or 4 in the PLL circuit (including phase detector, loop filtering, VCO and frequency divider) to obtain the LLC and LLC2 output clock signals. The rectangular output clocks have a 50% duty factor.

It is also possible to operate the OCF1 with an external CGC (SAA7197) providing the signals LLC and CREF. The selection of the internal/external CGC will be controlled by the CGCE input signal.

9.8 Power-on reset

Power-on reset is activated at power-on (using only internal CGC), when the supply voltage decreases below 3.5 V. The indicator output \overline{RESET} is LOW for a time. The \overline{RESET} signal can be applied to reset other circuits of the digital TV system.

9.9 RTCO output

The real time control and status output signal contains serial information about actual system clock, subcarrier frequency and PAL/SECAM sequence. The signal can be used for various applications in external circuits, for example, in a digital encoder to achieve clean encoding.

One Chip Front-end 1 (OCF1)

SAA7110; SAA7110A

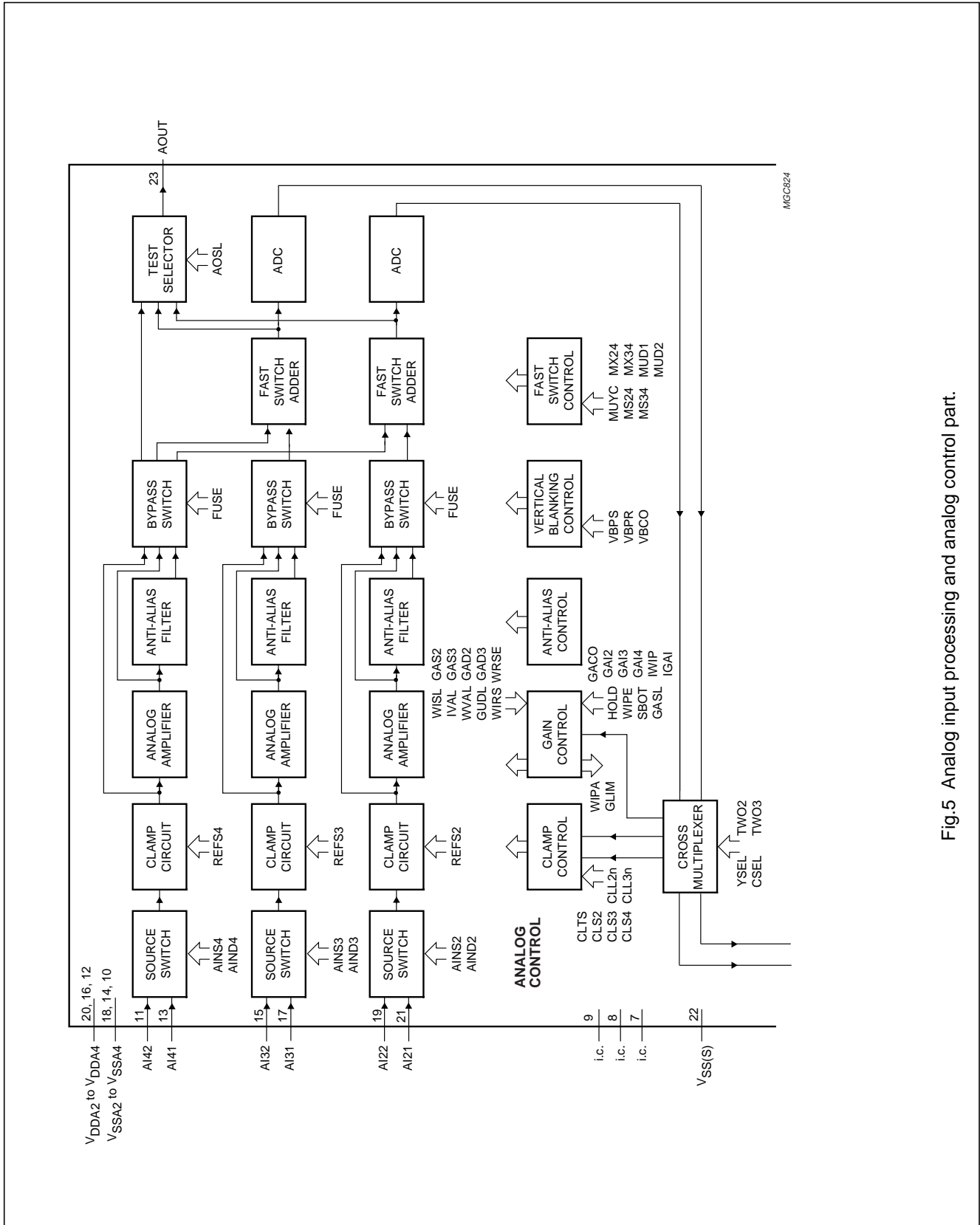

Fig.5 Analog input processing and analog control part.

One Chip Front-end 1 (OCF1)

SAA7110; SAA7110A

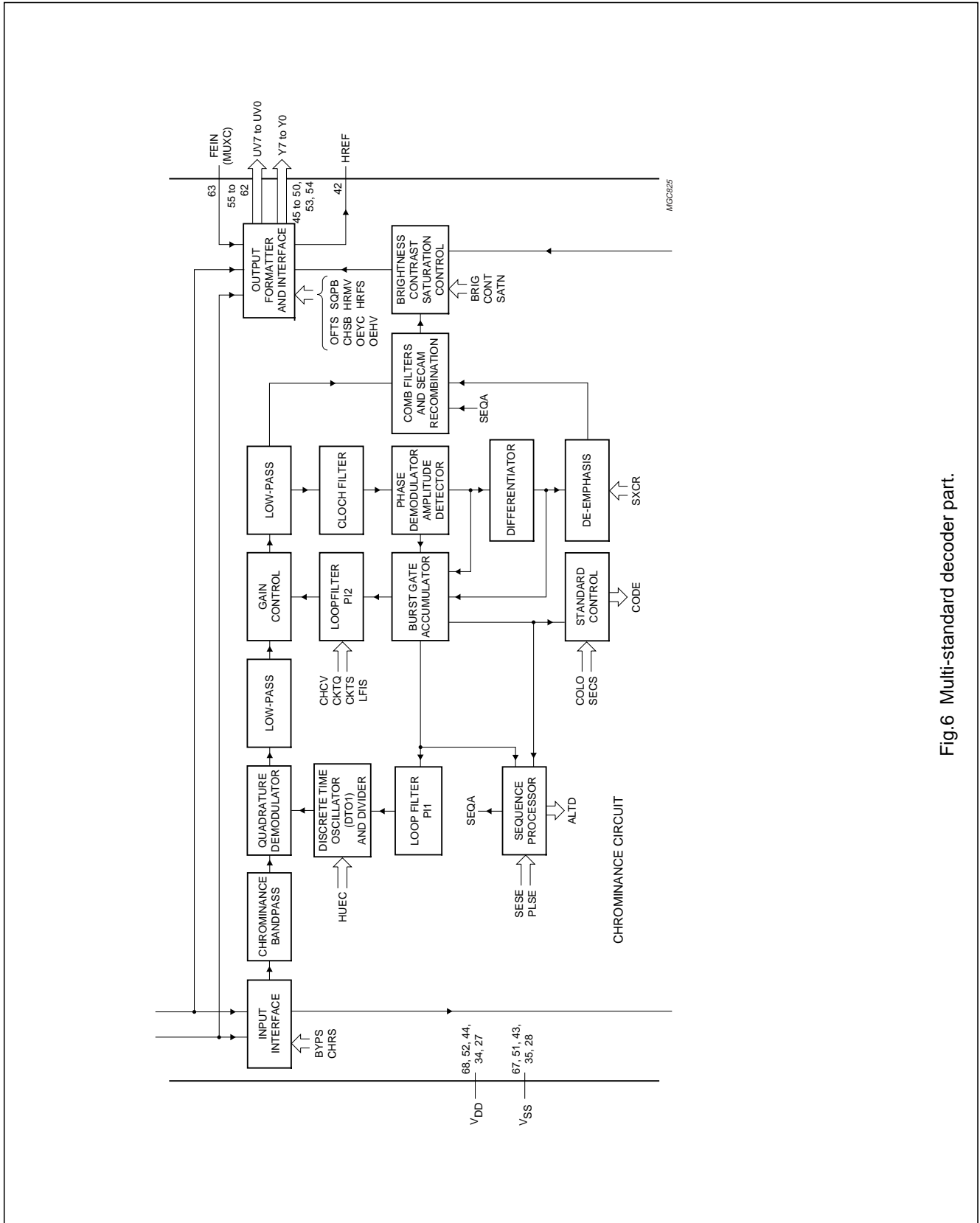
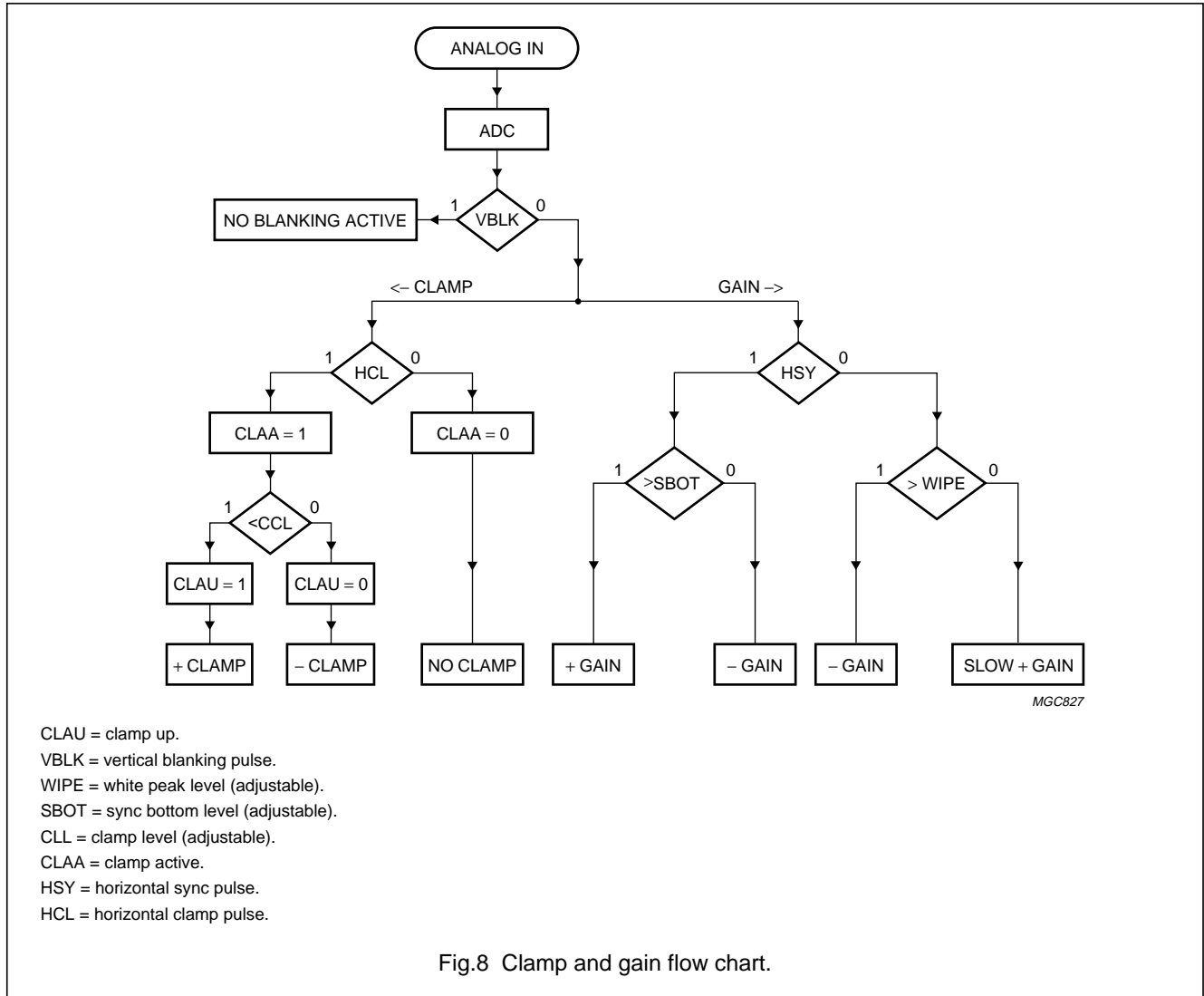

Fig.6 Multi-standard decoder part.

One Chip Front-end 1 (OCF1)

SAA7110; SAA7110A

10 GAIN CHARTS



One Chip Front-end 1 (OCF1)

SAA7110; SAA7110A

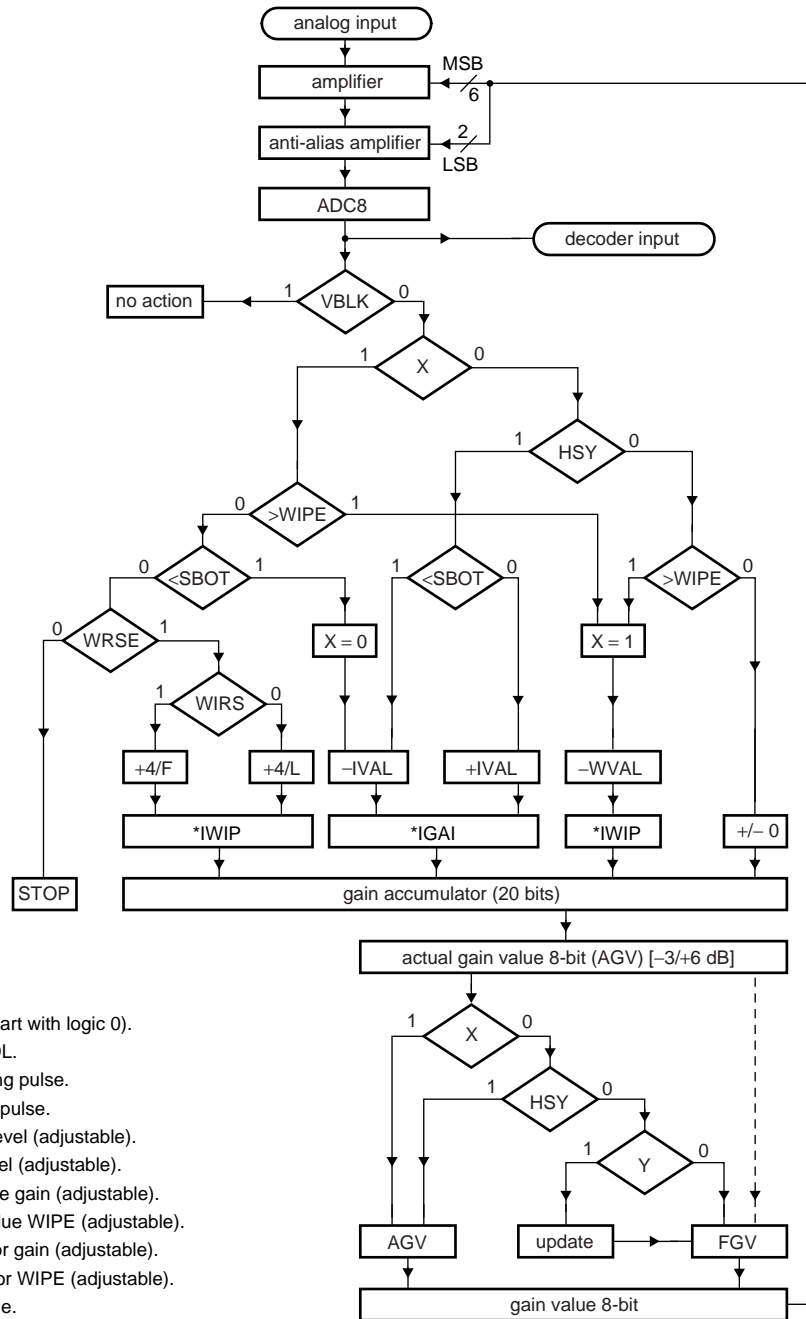

X = system variable (start with logic 0).
 Y = IAGV-FGVI > GUDL.
 VBLK = vertical blanking pulse.
 HSY = horizontal sync pulse.
 SBOT = sync bottom level (adjustable).
 WIPE = white peak level (adjustable).
 IVAL = integration value gain (adjustable).
 WVAL = integration value WIPE (adjustable).
 IGAI = integration factor gain (adjustable).
 IWIP = integration factor WIPE (adjustable).
 AGV = actual gain value.
 FGV = frozen gain value.
 GUDL = gain update level (adjustable).
 WRSE = white peak reset enable.
 WIRS = white peak reset select.
 L = line.
 F = field.

MGC828

Fig.9 Luminance AGC flow chart.

One Chip Front-end 1 (OCF1)

SAA7110; SAA7110A

11 LIMITING VALUES

In accordance with the Absolute Maximum Rating System (IEC 134); all ground pins and all supply pins connected together.

SYMBOL	PARAMETER	CONDITIONS	MIN.	MAX.	UNIT
V _{DDA}	analog supply voltage		-0.5	+7.0	V
V _{DDD}	digital supply voltage		-0.5	+7.0	V
V _{I(A)}	analog input voltage		-0.5	+7.0	V
V _{I(D)}	digital input voltage		-0.5	+7.0	V
V _{diff}	voltage difference between V _{SSAall} and V _{SSall}		-	100	mV
T _{stg}	storage temperature		-65	+150	°C
T _{amb}	operating ambient temperature		0	70	°C
T _{amb(bias)}	operating ambient temperature under bias		-10	+80	°C
P _{tot}	total power dissipation	V _{DDA} = V _{DDD} = 7 V; note 1	-	2.5	W
V _{esd}	electrostatic discharge all pins	note 2	-2000	+2000	V

Note

1. Compare with typical total power consumption in Chapter "Characteristics".
2. Equivalent to discharging a 100 pF capacitor through a 1.5 kΩ series resistor.

12 CHARACTERISTICS

V_{DDD} = 5 V; V_{DDA} = 5 V; T_{amb} = 25 °C; unless otherwise specified.

SYMBOL	PARAMETER	CONDITIONS	MIN.	TYP.	MAX.	UNIT
Supplies						
V _{DDA}	analog supply voltage		4.75	5.0	5.25	V
V _{DDD}	digital supply voltage		4.5	5.0	5.5	V
I _{DDA(tot)}	total analog supply current		-	-	150	mA
I _{DDD(tot)}	total digital supply current		-	-	250	mA
P _{tot}	total power dissipation		-	1.2	1.7	W
Analog part						
I _{clamp}	clamping current	V _I = 1.25 V DC	-2	-	+2	μA
V _{i(p-p)}	input voltage (peak-to-peak value), AC coupling required	C _{couple} = 10 nF	0.5	1.0	1.38	V
Z _i	input impedance	clamping current off	200	-	-	kΩ
C _i	input capacitance		-	-	10	pF
α _{ct}	channel crosstalk	f _i < 5 MHz	-	-50	-	dB
Analog-to-digital converters						
B	analog bandwidth	at -3 dB	-	15	-	MHz
φ _{diff}	differential phase	amplifier + AAF = bypass	-	2	-	deg
G _{diff}	differential gain	amplifier + AAF = bypass	-	2	-	%
f _{LLC}	ADC clock rate		11	-	16	MHz
DLE	DC differential linearity error		-	1/2	-	LSB
ILE	DC integral linearity error		-	1	-	LSB

One Chip Front-end 1 (OCF1)

SAA7110; SAA7110A

SYMBOL	PARAMETER	CONDITIONS	MIN.	TYP.	MAX.	UNIT
Digital inputs						
V _{IL}	LOW level input voltage SDA and SCL		-0.5	-	+1.5	V
V _{IH}	HIGH level input voltage SDA and SCL		3.0	-	V _{DD} + 0.5	V
V _{IL(clk)}	LOW level input voltage for clocks		-0.5	-	+0.6	V
V _{IH(clk)}	HIGH level input voltage for clocks		2.4	-	V _{DD} + 0.5	V
V _{IH(XTALI)}	HIGH level input voltage XTALI		3.0	-	V _{DD} + 0.5	V
V _{IL(n)}	LOW level input voltage all other inputs		-0.5	-	+0.8	V
V _{IH(n)}	HIGH level input voltage all other inputs		2.0	-	V _{DD} + 0.5	V
I _{LI}	input leakage current		-	-	10	μA
C _{i(clk)}	input capacitance for clocks		-	-	10	pF
C _{i(I/O)}	input capacitance	I/Os at high impedance	-	-	8	pF
C _{i(n)}	input capacitance all other inputs		-	-	8	pF
Digital outputs						
V _{LFCO}	LFCO output voltage (peak-to-peak value)	note 1	1.4	-	2.6	V
V _{OL}	LOW level output voltage	note 2	0	-	0.6	V
V _{OH}	HIGH level output voltage	note 2	2.4	-	V _{DD}	V
V _{OL(clk)}	LOW level output voltage for clocks		-0.5	-	+0.6	V
V _{OH(clk)}	HIGH level output voltage for clocks		2.6	-	V _{DD} + 0.5	V
Clock input timing (LLC)						
T _{cy}	cycle time		31	-	45	ns
δ	duty factor for t _{LLCH} /T _{cy}		40	-	60	%
t _r	rise time	V _i = 0.6 to 2.4 V	-	-	5	ns
t _f	fall time	V _i = 2.4 to 0.6 V	-	-	5	ns
Control and CREF input timing (note 3)						
t _{SU;DAT}	input data set-up time		11	-	-	ns
t _{HD;DAT}	input data hold time		3	-	-	ns
t _{HD;FEIN}	input data hold time for FEIN		3	-	-	ns
t _{HD;OTHER}	input data hold time all other inputs	note 3	6	-	-	ns

One Chip Front-end 1 (OCF1)

SAA7110; SAA7110A

SYMBOL	PARAMETER	CONDITIONS	MIN.	TYP.	MAX.	UNIT
Data and control output timing (note 4)						
$C_{L(data)}$	output load capacitance (data, HREF and VS)		15	–	50	pF
$C_{L(control)}$	output load capacitance (control)		7.5	–	25	pF
$t_{HD;DAT}$	output data hold time	$C_L = 15 \text{ pF}$	13	–	–	ns
$t_{PD(data)}$	propagation delay from negative edge of LLC (data, HREF and VS)	$C_L = 50 \text{ pF}$	–	–	29	ns
$t_{PD(control)}$	propagation delay from negative edge of LLC (control)	$C_L = 25 \text{ pF}$	–	–	29	ns
$t_{PD(Z)}$	propagation delay from negative edge of LLC (to 3-state)	note 5	–	–	15	ns
Clock output timing (LLC and LLC2)						
$C_{L(LLC)}$	output load capacitance		15	–	40	pF
T_{cy}	cycle time	LLC	31.5	–	45	ns
		LLC2	63	–	90	ns
δ	duty factors for t_{LLCH}/t_{LLC} and t_{LLC2H}/t_{LLC2}		40	–	60	%
t_r	rise time	0.6 to 2.6 V	–	–	5	ns
t_f	fall time	2.6 to 0.6 V	–	–	5	ns
t_d	delay time LLC output to LLC2 output	$V_i = 1.5 \text{ V};$ $C_{LLC/LLC2} = 40 \text{ pF};$ note 6	–	–	8	ns
Data qualifier output timing (CREF)						
$t_{HD;CREF}$	output hold time	$C_L = 15 \text{ pF}$	4	–	–	ns
$t_{PD;CREF}$	propagation delay from positive edge of LLC	$C_L = 40 \text{ pF}$	–	–	20	ns
Horizontal PLL						
f_{Hnom}	nominal line frequency	50 Hz field	–	15625	–	Hz
		60 Hz field	–	15734	–	Hz
$\Delta f_H/f_{Hnom}$	permissible static deviation	50 Hz field	–	–	5.6	%
		60 Hz field	–	–	6.7	%
Subcarrier PLL						
f_{Hnom}	nominal subcarrier frequency	PAL	–	4433618	–	Hz
		NTSC	–	3579545	–	Hz
$\Delta f_H/f_{Hnom}$	lock-in range		400	–	–	Hz

One Chip Front-end 1 (OCF1)

SAA7110; SAA7110A

SYMBOL	PARAMETER	CONDITIONS	MIN.	TYP.	MAX.	UNIT
Crystal oscillator						
f_n	nominal frequency	3rd harmonic	–	26.8	–	MHz
$\Delta f/f_n$	permissible frequency deviation		-50×10^{-6}	–	$+50 \times 10^{-6}$	
$\Delta T/f_n$	permissible frequency deviation with temperature		-20×10^{-6}	–	$+20 \times 10^{-6}$	
CRYSTAL SPECIFICATION (X1); note 7						
T_{amb}	operating ambient temperature		0	–	70	°C
C_L	load capacitance		8	–	–	pF
R_s	series resonance resistance		–	50	80	Ω
C1	motional capacitance		–	$1.1 \pm 20\%$	–	fF
C0	parallel capacitance		–	$3.5 \pm 20\%$	–	pF

Notes

- The LFCO output level must be measured with a load circuit of 10 k Ω in parallel with 15 pF.
- The levels must be measured with load circuits, the loads depend on the type of output stage. Control outputs (except HREF and VS); 1.2 k Ω at 3 V (TTL load); $C_L = 25$ pF: data outputs (plus HREF and VS); 1.2 k Ω at 3 V (TTL load); $C_L = 50$ pF.
- Other control input signals are CGCE, VS, SA, HCL and HSY.
- Data output signals are YUV (15 to 0). Control output signals are HREF, VS, HS, HSY, HCL, RTCO, PLIN (HL), ODD (VL) and GPSW0 (VBLK). The effects of rise and fall times are included in the calculation of $t_{HD,DAT}$, t_{PD} and t_{PDZ} . Timings and levels refer to drawings and conditions illustrated in Fig.10.
- The minimum propagation delay from 3-state to data active related to falling edge of LLC is 0 ns.
- LLC2 is not active while CGCE = 0.
- Philips catalogue number 9922 520 30004.

Table 1 Processing delay

FUNCTION	TYPICAL ANALOG DELAY AI21 TO ADCIN (AOUT) (ns)	DIGITAL DELAY ADCIN (AOUT) TO YUVOUT (1/LLC) (YDEL = 0; CAD2/3 = 1)
Without amplifier or anti-alias filter	10	248
With amplifier, without anti-alias filter	30	
With amplifier plus anti-alias filter (50 Hz)	30 + 40	
With amplifier plus anti-alias filter (60 Hz)	30 + 50	

One Chip Front-end 1 (OCF1)

SAA7110; SAA7110A

13 TIMING

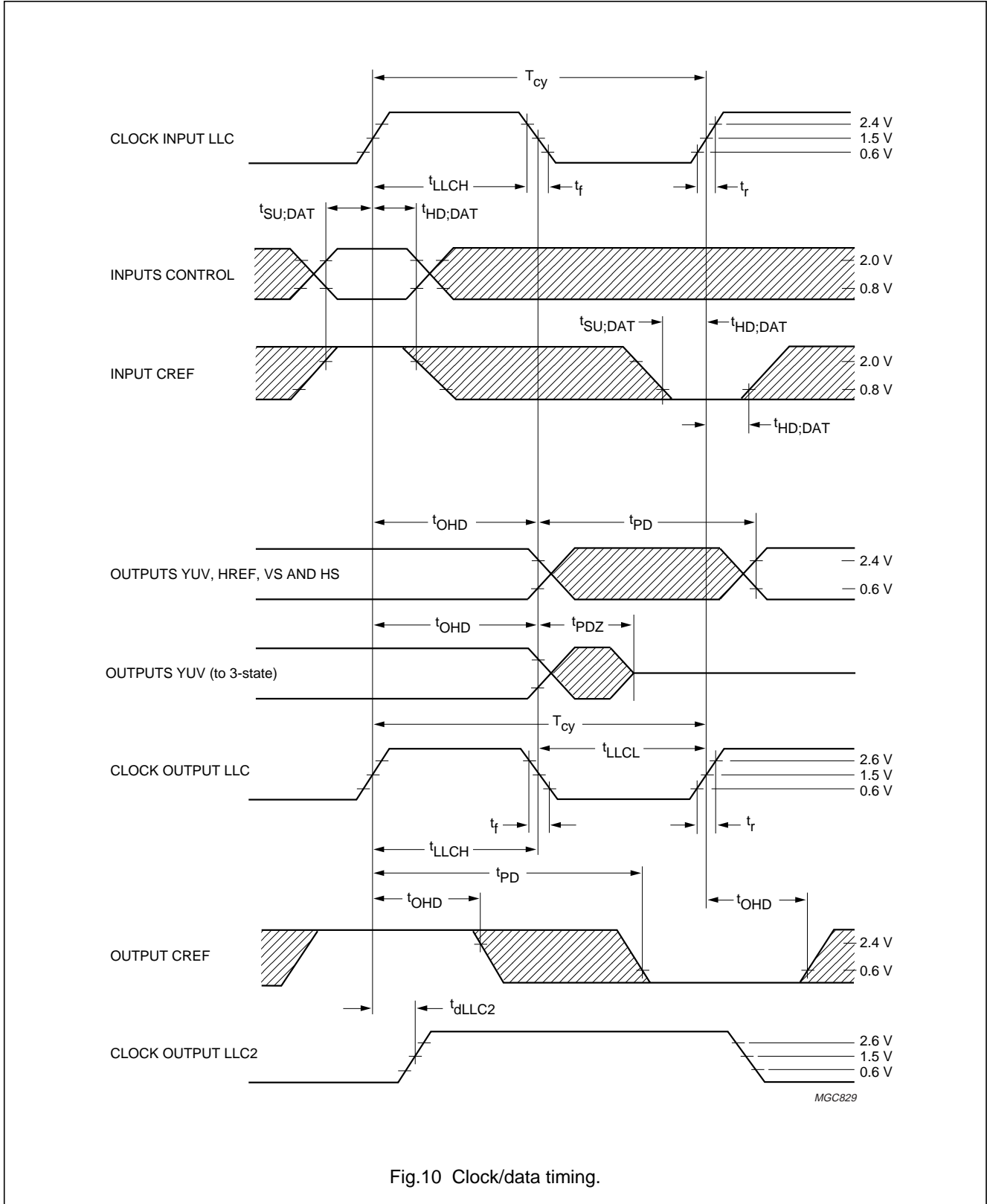
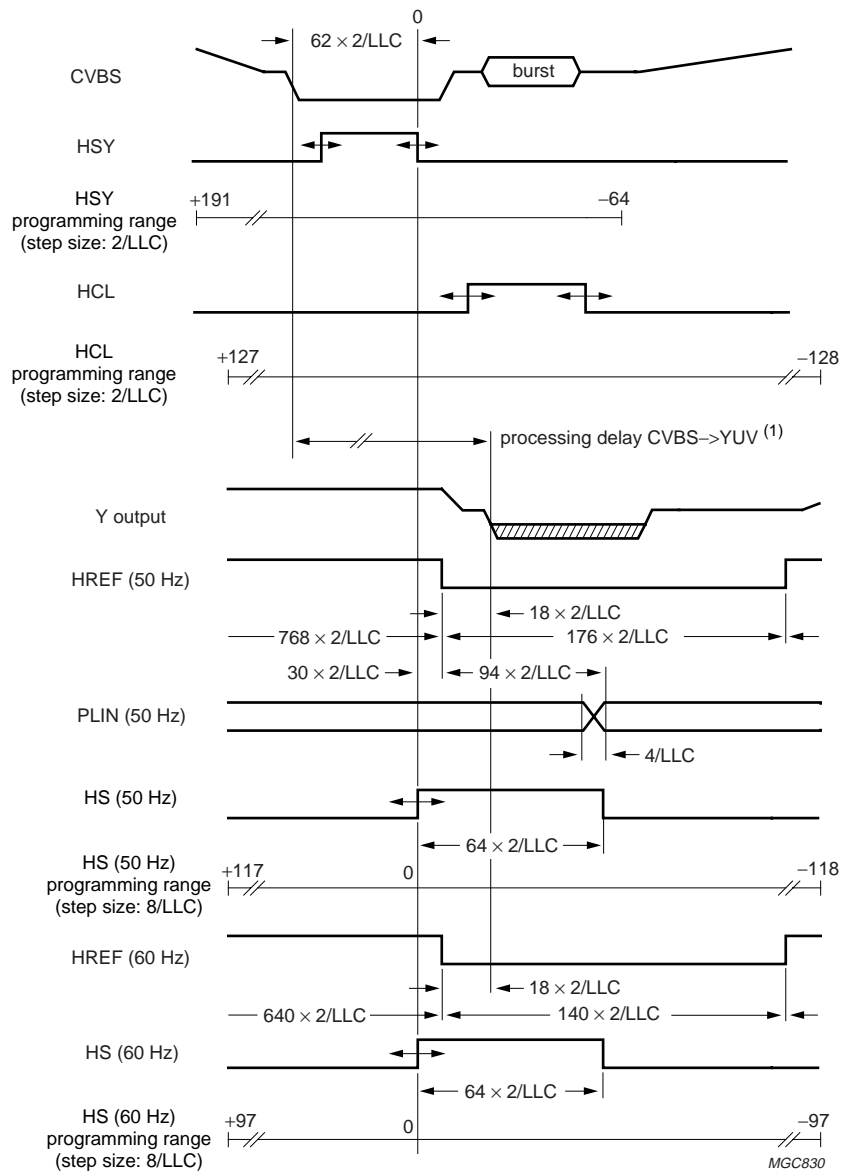

Fig.10 Clock/data timing.

One Chip Front-end 1 (OCF1)

SAA7110; SAA7110A



(1) See Table 1.
HRMV = 1 and HRFS = 0.

Fig.11 Horizontal timing.

One Chip Front-end 1 (OCF1)

SAA7110; SAA7110A

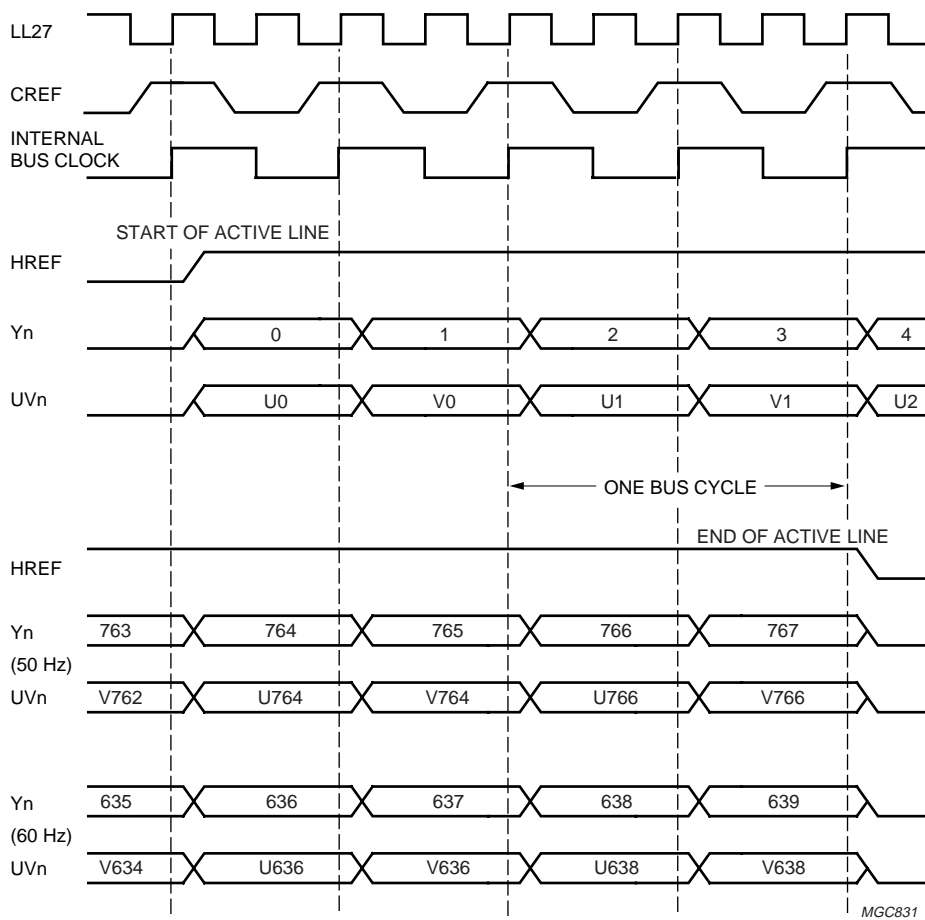
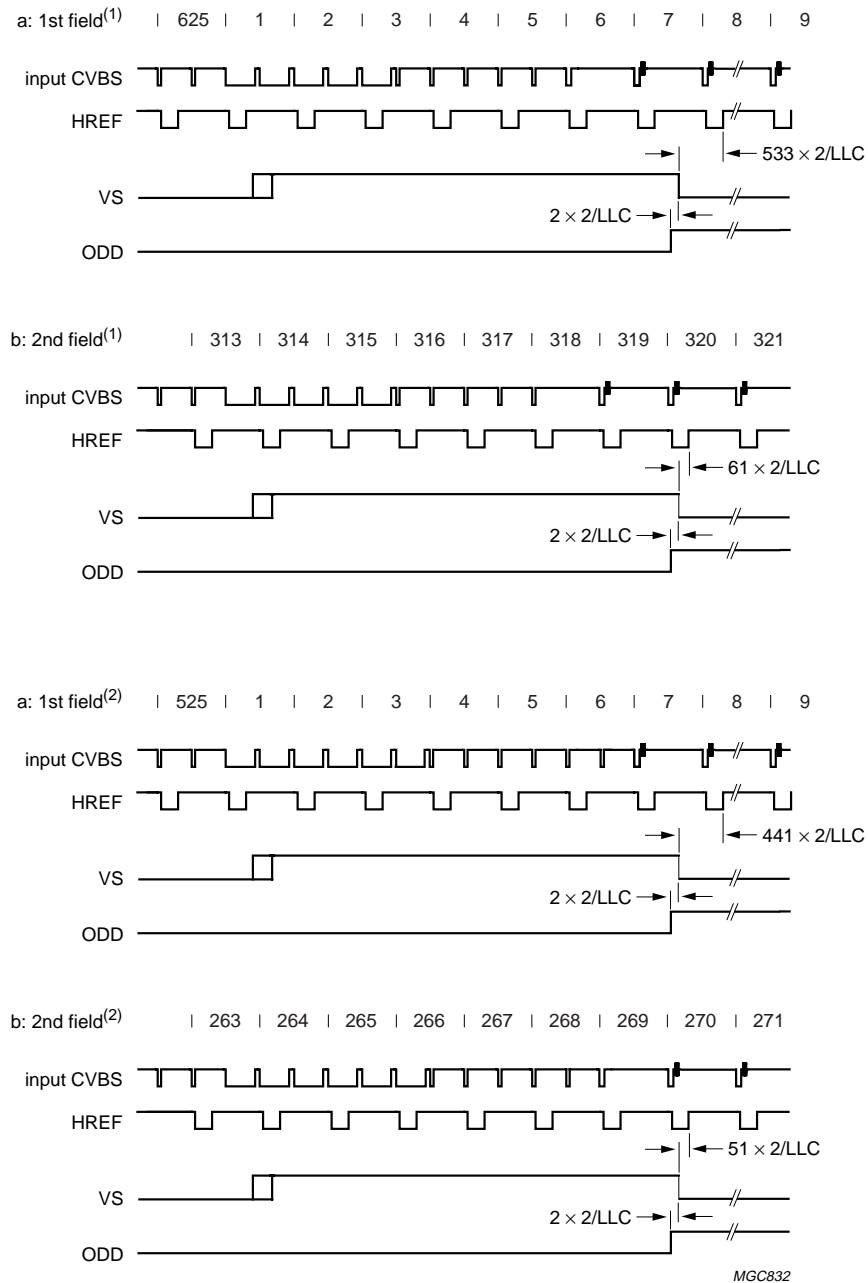

Fig.12 HREF timing.

One Chip Front-end 1 (OCF1)

SAA7110; SAA7110A



(1) Nominal input signal 50 Hz.
 (2) Nominal input signal 60 Hz.
 HRMV = 1 and HRFS = 0.

Fig.13 Vertical timing.

One Chip Front-end 1 (OCF1)

SAA7110; SAA7110A

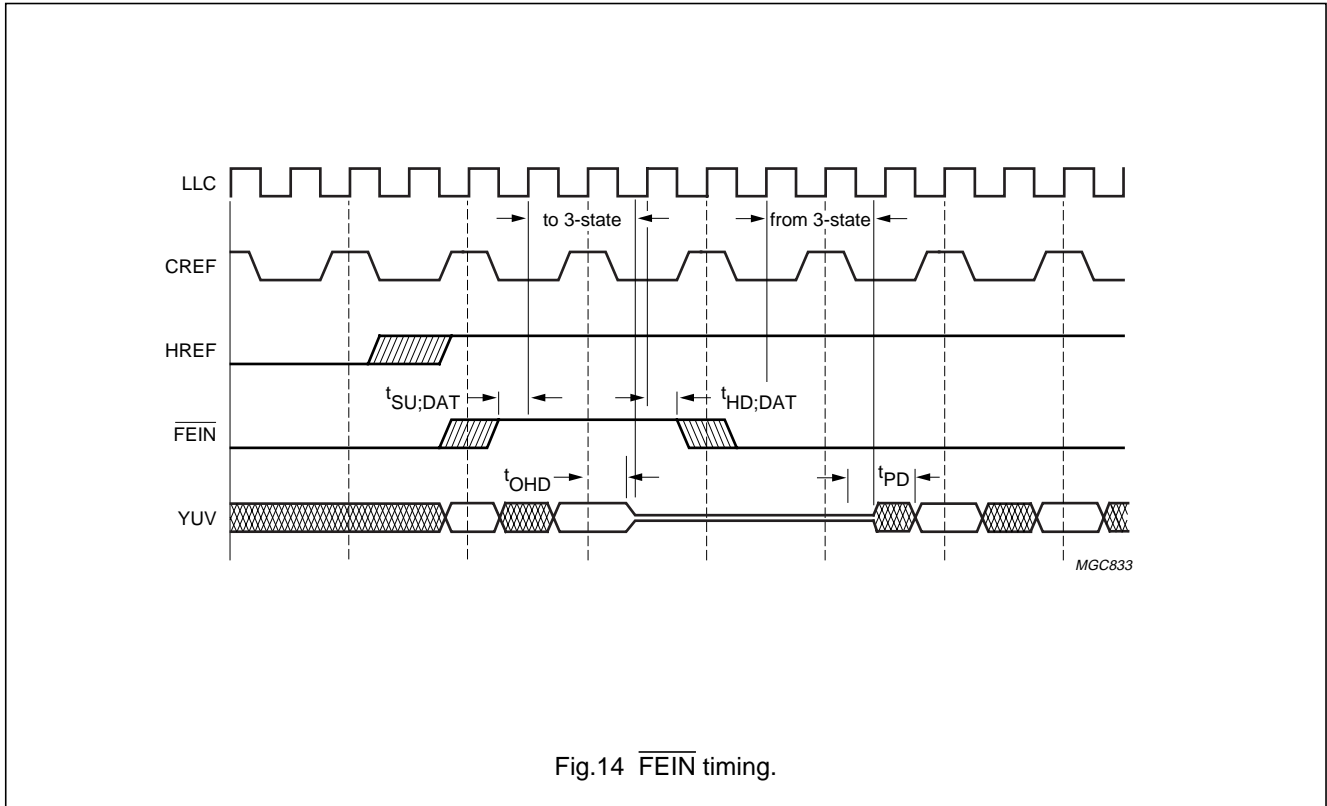

Fig.14 FEIN timing.

Table 2 Digital output control

OEYC	FEIN	YUV (15 : 0)
0	0	Z
1	0	active
X	1	Z

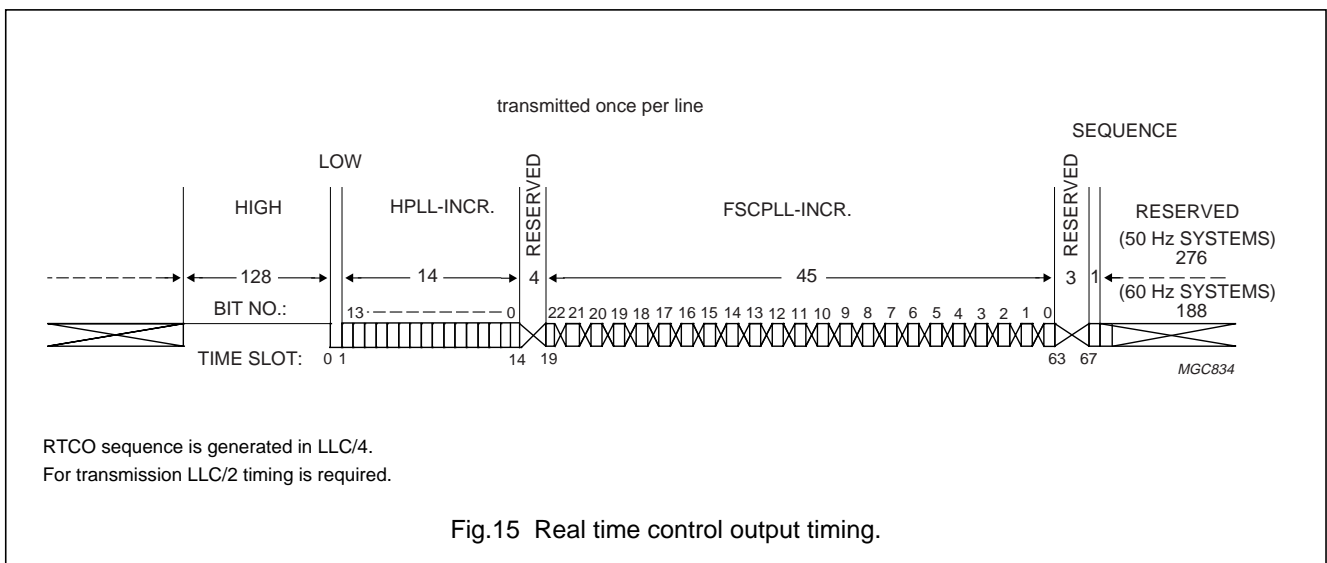

Fig.15 Real time control output timing.

One Chip Front-end 1 (OCF1)

SAA7110; SAA7110A

14 OUTPUT FORMATS

Table 3 Output formats

BUS SIGNAL	PIXEL BYTE SEQUENCE 4 : 1 : 1 FORMAT								PIXEL BYTE SEQUENCE 4 : 2 : 2 FORMAT					
	Y7	Y7	Y7	Y7	Y7	Y7	Y7	Y7	Y7	Y7	Y7	Y7	Y7	Y7
Y6	Y6	Y7	Y6	Y6	Y6	Y6	Y6	Y6	Y6	Y6	Y6	Y6	Y6	Y6
Y5	Y5	Y5	Y5	Y5	Y5	Y5	Y5	Y5	Y5	Y5	Y5	Y5	Y5	Y5
Y4	Y4	Y4	Y4	Y4	Y4	Y4	Y4	Y4	Y4	Y4	Y4	Y4	Y4	Y4
Y3	Y3	Y3	Y3	Y3	Y3	Y3	Y3	Y3	Y3	Y3	Y3	Y3	Y3	Y3
Y2	Y2	Y2	Y2	Y2	Y2	Y2	Y2	Y2	Y2	Y2	Y2	Y2	Y2	Y2
Y1	Y1	Y1	Y1	Y1	Y1	Y1	Y1	Y1	Y1	Y1	Y1	Y1	Y1	Y1
Y0	Y0	Y0	Y0	Y0	Y0	Y0	Y0	Y0	Y0	Y0	Y0	Y0	Y0	Y0
UV7	U7	U5	U3	U1	U7	U5	U3	U1	U7	V7	U7	V7	U7	V7
UV6	U6	U4	U2	U0	U6	U4	U2	U0	U6	V6	U6	V6	U6	V6
UV5	V7	V5	V3	V1	V7	V5	V3	V1	U5	V5	U5	V5	U5	V5
UV4	V6	V4	V2	V0	V6	V4	V2	V0	U4	V4	U4	V4	U4	V4
UV3	0	0	0	0	0	0	0	0	U3	V3	U3	V3	U3	V3
UV2	0	0	0	0	0	0	0	0	U2	V2	U2	V2	U2	V2
UV1	0	0	0	0	0	0	0	0	U1	V1	U1	V1	U1	V1
UV0	0	0	0	0	0	0	0	0	U0	V0	U0	V0	U0	V0
Y frame	0	1	2	3	4	5	6	7	0	1	2	3	4	5
UV frame	0				4				0		2		4	
	data rate				sample frequency				data rate		sample frequency			
Y	LLC2				LLC2				LLC2		LLC2			
U					LLC4						LLC8			
V					LLC4						LLC8			

One Chip Front-end 1 (OCF1)

SAA7110; SAA7110A

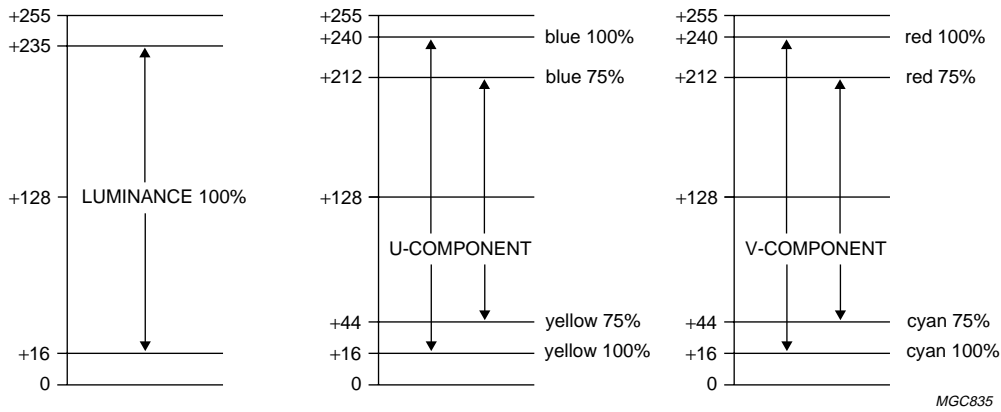

a. Y output range.

b. U output range (B-Y).

c. Y output range (R-Y).

CCIR 601 digital levels.

Fig.16 YUV output signal range.

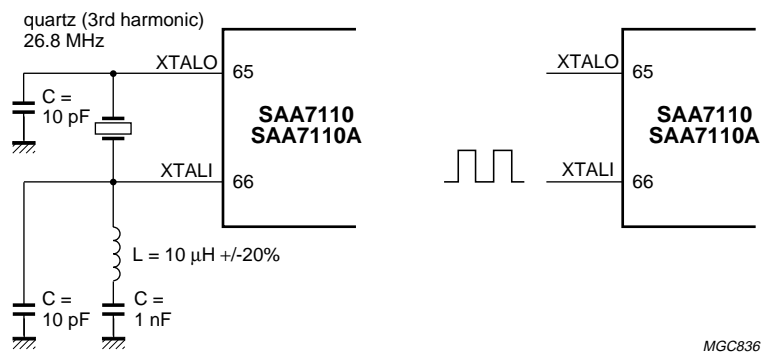

a. with quartz crystal.

b. with external clock.

Fig.17 Oscillator application.

One Chip Front-end 1 (OCF1)

SAA7110; SAA7110A

15 CLOCK SYSTEM

15.1 Clock generation circuit

The internal CGC generates the system clocks LLC, LLC2 and the clock reference signal CREF. The internally generated LFCO (triangular waveform) is multiplied by four via the analog PLL (including phase detector, loop filter, VCO and frequency divider). The rectangular output signals have a 50% duty factor.

Table 4 System clock frequencies

CLOCK	FREQUENCY (MHz)	
	50 Hz	60 Hz
XTAL	26.8	26.8
LLC	29.5	24.545454
LLC2	14.75	12.272727
LLC4	7.375	6.136136
LLC8	3.6875	3.068181

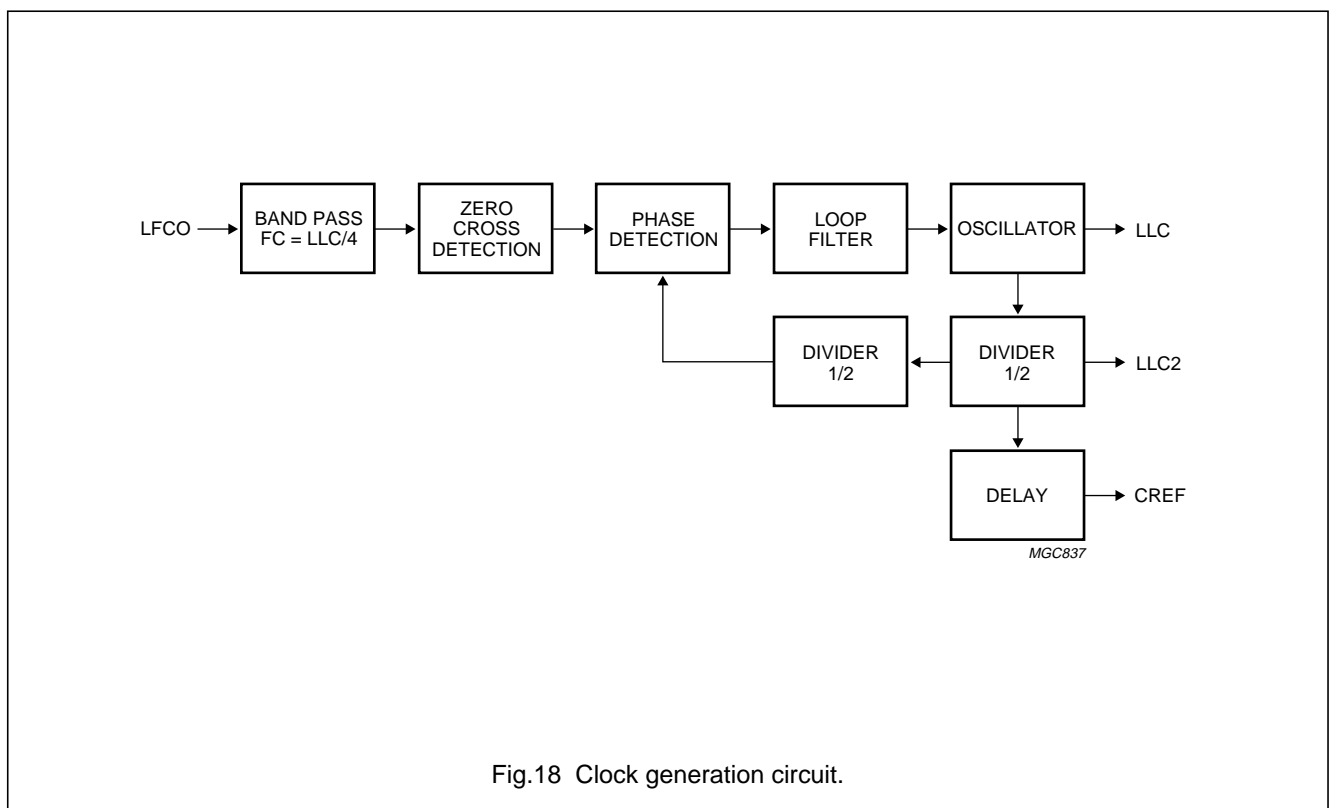

Fig.18 Clock generation circuit.

One Chip Front-end 1 (OCF1)

SAA7110; SAA7110A

15.2 Power-on control

Power-on reset is activated at power-on (using only internal CGC) and if the supply voltage falls below 3.5 V. The $\overline{\text{RESET}}$ signal can be applied to reset other circuits of the digital TV system.

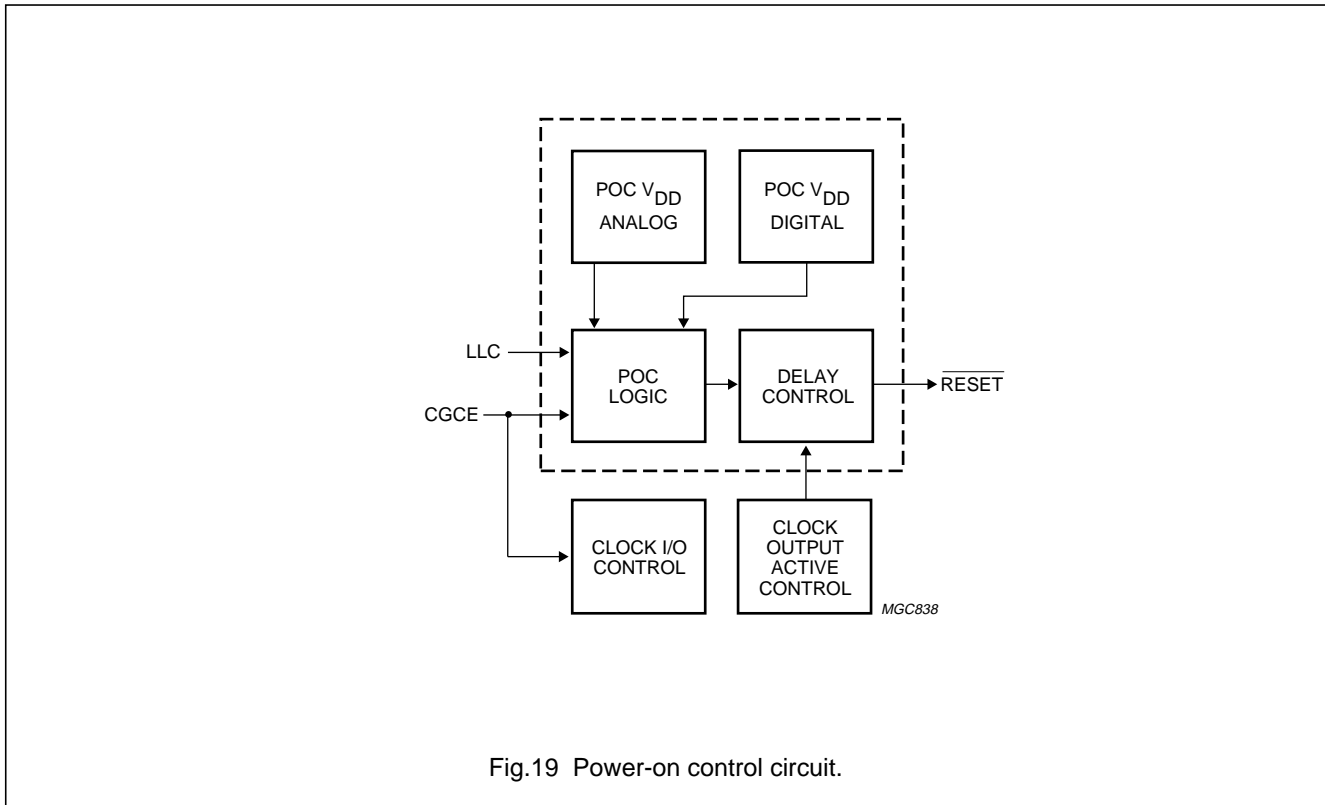

Fig.19 Power-on control circuit.

Table 5 Power-on control sequence

INTERNAL POWER-ON CONTROL SEQUENCE	PIN OUTPUT STATUS	FUNCTION
Directly after power-on asynchronous reset	Y7 to Y0, UV7 to UV0, RTCO, PLIN, ODD, GPSW, SDA, HREF, HS, VS, HCL and HSY in high impedance state LLC, LLC2 and CREF in HIGH state	direct switching to high impedance (outputs) or input mode (I/Os) for 20 to 200 ms
Start synchronous I ² C-bus reset sequence	LLC, LLC2 and CREF active	starting I ² C-bus reset sequence
Status after I ² C-bus reset	Y7 to Y0, UV7 to UV0, HREF and HS held in high impedance state VS, HCL and HSY held in input function mode	SA0DH = 7DH (VTRC = 0, RTSE = 1, HRMV = 1, SSTB = 0, SECS = 1) SA0EH = 00H (HPLL = 0, OEHV = 0, OEYC = 0, CHRIS = 0, GPSW = 0) SA31H = 00H (AOSL 1 : 0 = 00, WIRS = 0, WRSE = 0, SQPB = 0, VBLKA = 0, PULIO = 0)
Status after power-on control sequence	RTCO, PLIN, ODD, GPSW and SDA active	after power-on (reset sequence) a complete I ² C-bus transmission is required

One Chip Front-end 1 (OCF1)

SAA7110; SAA7110A

16 I²C-BUS DESCRIPTION

16.1 I²C-bus format

S	SLAVE ADDRESS	ACK	SUBADDRESS	ACK	DATA (n bytes)	ACK	P
---	---------------	-----	------------	-----	----------------	-----	---

Table 6 Description of I²C-bus format

CODE	DESCRIPTION
S	START condition
Slave address	1001 110Xb (SA = LOW) or 1001 111Xb (SA = HIGH)
ACK	acknowledge generated by the slave
Subaddress	subaddress byte, see Table 7
Data	data byte, see Table 7; note 1
P	STOP condition
X	read/write control bit: X = 0, order to write (the circuit is slave receiver) X = 1, order to read (the circuit is slave transmitter)
Slave address	9CH for write, 9DH for read (SA = 0)
	9EH for write, 9FH for read (SA = 1)
Subaddress	00H to 19H decoder part
	1AH to 1FH reserved
	20H to 34H front-end part

Note

1. If more than one byte DATA is transmitted then the auto-increment of the subaddress is performed.

One Chip Front-end 1 (OCF1)

SAA7110; SAA7110A

16.2 I²C-bus receiver/transmitter tables

Table 7 OCF1 RECEIVER

Slave address 10011100b, 9CH (SA = 0) and 10011110b, 9EH (SA = 1)

REGISTER FUNCTION	SUB ADD ⁽¹⁾	DATA BYTE ⁽²⁾							
		D7	D6	D5	D4	D3	D2	D1	D0
DMSD-SQP + BSC slave receiver (SU 00H to 19H)									
Increment delay	00	007 IDEL7	006 IDEL6	005 IDEL5	004 IDEL4	003 IDEL3	002 IDEL2	001 IDEL1	000 IDEL0
HSY begin 50 Hz	01	015 HSYB7	014 HSYB6	013 HSYB5	012 HSYB4	011 HSYB3	010 HSYB2	009 HSYB1	008 HSYB0
HSY stop 50 Hz	02	023 HSYS7	022 HSYS6	021 HSYS5	020 HSYS4	019 HSYS3	018 HSYS2	017 HSYS1	016 HSYS0
HCL begin 50 Hz	03	031 HCLB7	030 HCLB6	029 HCLB5	028 HCLB4	027 HCLB3	026 HCLB2	025 HCLB1	024 HCLB0
HCL stop 50 Hz	04	039 HCLS7	038 HCLS6	037 HCLS5	036 HCLS4	035 HCLS3	034 HCLS2	033 HCLS1	032 HCLS0
HSY after PHI1 50 Hz	05	047 HPHI7	046 HPHI6	045 HPHI5	044 HPHI4	043 HPHI3	042 HPHI2	041 HPHI1	040 HPHI0
Luminance control	06	055 BYPS	054 PREF	053 BPSS1	052 BPSS0	051 CORI1	050 CORI0	049 APER1	048 APER0
Hue control	07	063 HUEC7	062 HUEC6	061 HUEC5	060 HUEC4	059 HUEC3	058 HUEC2	057 HUEC1	056 HUEC0
Colour killer threshold QUAM (PAL/NTSC)	08	071 CKTQ4	070 CKTQ3	069 CKTQ2	068 CKTQ1	067 CKTQ0	066 XXX	065 XXX	064 XXX
Colour killer threshold SECAM	09	079 CKTS4	078 CKTS3	077 CKTS2	076 CKTS1	075 CKTS0	074 XXX	073 XXX	072 XXX
PAL switch sensitivity	0A	087 PLSE7	086 PLSE6	085 PLSE5	084 PLSE4	083 PLSE3	082 PLSE2	081 PLSE1	080 PLSE0
SECAM switch sensitivity	0B	095 SESE7	094 SESE6	093 SESE5	092 SESE4	091 SESE3	090 SESE2	089 SESE1	088 SESE0
Gain control chrominance	0C	103 COLO	102 LFIS1	101 LFIS0	100 XXX	099 XXX	098 XXX	097 XXX	096 XXX
Standard/mode control	0D	111 VTRC	110 XXX	109 XXX	108 XXX	107 RTSE	106 HRMV	105 SSTB	104 SECS
I/O and clock control	0E	119 HPLL	118 XXX	117 XXX	116 OEHV	115 OEYC	114 CHRS	113 XXX	112 GPSW
Control #1	0F	127 AUFD	126 FSEL	125 SXCR	124 SCEN	123 XXX	122 YDEL2	121 YDEL1	120 YDEL0
Control #2	10	135 XXX	134 XXX	133 XXX	132 XXX	131 XXX	130 HRFS	129 VNOI1	128 VNOI0
Chrominance gain reference	11	143 CHCV7	142 CHCV6	141 CHCV5	140 CHCV4	139 CHCV3	138 CHCV2	137 CHCV1	136 CHCV0
Chrominance saturation	12	151 SATN7	150 SATN6	149 SATN5	148 SATN4	147 SATN3	146 SATN2	145 SATN1	144 SATN0

One Chip Front-end 1 (OCF1)

SAA7110; SAA7110A

REGISTER FUNCTION	SUB ADD ⁽¹⁾	DATA BYTE ⁽²⁾							
		D7	D6	D5	D4	D3	D2	D1	D0
Luminance contrast	13	159 CONT7	158 CONT6	157 CONT5	156 CONT4	155 CONT3	154 CONT2	153 CONT1	152 CONT0
HSY begin 60 Hz	14	167 HS6B7	166 HS6B6	165 HS6B5	164 HS6B4	163 HS6B3	162 HS6B2	161 HS6B1	160 HS6B0
HSY stop 60 Hz	15	175 HS6S7	174 HS6S6	173 HS6S5	172 HS6S4	171 HS6B3	170 HS6S2	169 HS6S1	168 HS6S0
HCL begin 60 Hz	16	183 HC6B7	182 HC6B6	181 HC6B5	180 HCLB4	179 HC6B3	178 HC6B2	177 HC6B1	176 HC6B0
HCL stop 60 Hz	17	191 HC6S7	190 HC6S6	189 HC6S5	188 HC6S4	187 HC6S3	186 HC6S2	185 HC6S1	184 HC6S0
HSY after PHI1 60 Hz	18	199 HP6I7	198 HP6I6	197 HP6I5	196 HP6I4	195 HP6I3	194 HP6I2	193 HP6I1	192 HP6I0
Luminance brightness	19	207 BRIG7	206 BRIG6	205 BRIG5	204 BRIG4	203 BRIG3	202 BRIG2	201 BRIG1	200 BRIG0
DUAD slave receiver (SU 20H to 32H)									
Analog control #1	20	007 AIND4	006 AIND3	005 AIND2	004 FUSE1	003 FUSE0	002 AINS4	001 AINS3	000 AINS2
Analog control #2	21	015 VBCO	014 MS34	013 MX241	012 MX240	011 MS24	010 REFS4	009 REFS3	008 REFS2
Mixer control #1	22	023 GACO1	022 GACO0	021 CSEL	020 YSEL	019 MUYC	018 CLTS	017 MX341	016 MX340
Clamping level control 21	23	031 CLL217	030 CLL216	029 CLL215	028 CLL214	027 CLL213	026 CLL212	025 CLL211	024 CLL210
Clamping level control 22	24	039 CLL227	038 CLL226	037 CLL225	036 CLL224	035 CLL223	034 CLL222	033 CLL221	032 CLL220
Clamping level control 31	25	047 CLL317	046 CLL316	045 CLL315	044 CLL314	043 CLL313	042 CLL312	041 CLL311	040 CLL310
Clamping level control 32	26	055 CLL327	054 CLL326	053 CLL325	052 CLL324	051 CLL323	050 CLL322	049 CLL321	048 CLL320
Gain control analog #1	27	063 HOLD	062 GASL	061 GAI25	060 GAI24	059 GAI23	058 GAI22	057 GAI21	056 GAI20
White peak control	28	071 WIPE7	070 WIPE6	069 WIPE5	068 WIPE4	067 WIPE3	066 WIPE2	065 WIPE1	064 WIPE0
Sync bottom control	29	079 SBOT7	078 SBOT6	077 SBOT5	076 SBOT4	075 SBOT3	074 SBOT2	073 SBOT1	072 SBOT0
Gain control analog #2	2A	087 IWIP1	086 IWIP0	085 GAI35	084 GAI34	083 GAI33	082 GAI32	081 GAI31	080 GAI30
Gain control analog #3	2B	095 IGAI1	094 IGAI0	093 GAI45	092 GAI44	091 GAI43	090 GAI42	089 GAI41	088 GAI40
Mixer control #2	2C	103 CLS4	102 XXX	101 CLS3	100 CLS2	099 XXX	098 XXX	097 TWO3	096 TWO2
Integration value gain	2D	111 IVAL7	110 IVAL6	109 IVAL5	108 IVAL4	107 IVAL3	106 IVAL2	105 IVAL1	104 IVAL0

One Chip Front-end 1 (OCF1)

SAA7110; SAA7110A

REGISTER FUNCTION	SUB ADD ⁽¹⁾	DATA BYTE ⁽²⁾							
		D7	D6	D5	D4	D3	D2	D1	D0
Vertical blanking pulse set	2E	119 VBPS7	118 VBPS6	117 VBPS5	116 VBPS4	115 VBPS3	114 VBPS2	113 VBPS1	112 VBPS0
Vertical blanking pulse reset	2F	127 VBPR7	126 VBPR6	125 VBPR5	124 VBPR4	123 VBPR3	122 VBPR2	121 VBPR1	120 VBPR0
ADCs gain control	30	135 XXX	134 WISL	133 GAS3	132 GAD31	131 GAD30	130 GAS2	129 GAD21	128 GAD20
Mixer control #3	31	143 AOSL1	142 AOSL0	141 WIRS	140 WRSE	139 SQPB	138 ⁽³⁾ AFCCS	137 VBLKA	136 PULIO
Integration value white peak	32	151 WVAL7	150 WVAL6	149 WVAL5	148 WVAL4	147 WVAL3	146 WVAL2	145 WVAL1	144 WVAL0
Mixer control #4	33	159 OFTS	158 XXX	157 CHSB	156 XXX	155 CAD3	154 CAD2	153 XXX	152 XXX
Gain update level	34	167 MUD2	166 MUD1	165 GUDL5	164 GUDL4	163 GUDL3	162 GUDL2	161 GUDL1	160 GUDL0

Notes

- Subaddresses to be reset: 0D to 7DH, 0E and 31 to 00H after $\overline{\text{RESET}} = 0$ (CGCE = 0) or power-on (CGCE = 1).
- All reserved XXX-bits must be set to LOW, XX-bit is don't care.
- AFCCS bit does not exist in SAA7110A due to advanced anti-alias filter characteristic, don't care (XX).

Table 8 OCF1 TRANSMITTER: Byte number 0 (transmitted if SSTB = 0 or after $\overline{\text{RESET}}$ has been 0)

Slave address 10011101b, 9DH (SA = 0) and 10011111b, 9FH (SA = 1)

VERSION STATUS BYTE	D7	D6	D5	D4	D3	D2	D1	D0
ID7 to ID0; note 1	ID7	ID6	ID5	ID4	ID3	ID2	ID1	ID0

Note

- ID7 to ID0 indicates the version number of the IC, for example SAA7110A V1 = 01H.

Table 9 OCF1 TRANSMITTER: Byte number 1 (transmitted if SSTB = 1)

Slave address 10011101b, 9DH (SA = 0) and 10011111b, 9FH (SA = 1)

STATUS BYTE FUNCTION	D7	D6	D5	D4	D3	D2	D1	D0
See Table 10 for explanation of bits	STTC	HLCK	FIDT	GLIM	XXX	WIPA	ALTD	CODE

One Chip Front-end 1 (OCF1)

SAA7110; SAA7110A

Table 10 Explanation of bits shown in Table 9

BIT	DESCRIPTION
STTC	Status bit for horizontal time constant: LOW = TV time constant; HIGH = VCR time constant.
HLCK	Status bit for locked horizontal frequency: LOW = locked; HIGH = unlocked.
FIDT	Identification bit for detected field frequency: LOW = 50 Hz; HIGH = 60 Hz.
GLIM	Gain value for active luminance is limited (maximum or minimum), active HIGH.
XXX	reserved
WIPA	White peak loop is activated, active HIGH.
ALTD	Status HIGH: line alternating colour burst has been detected (PAL or SECAM).
CODE	Status HIGH: any colour signal has been detected.

16.3 I²C-bus detail

The I²C-bus receiver slave address is 9CH/9EH.

DMSD-SQP slave receiver (SU 00H to 19H).

16.3.1 SUBADDRESS 00 (DATA BYTE 007 to 000)

Table 11 Increment delay IDEL

DECIMAL MULTIPLIER	DELAY TIME (STEP SIZE = 4/LLC)	CONTROL BITS ⁽¹⁾							
		IDEL7	IDEL6	IDEL5	IDEL4	IDEL3	IDEL2	IDEL1	IDEL0
-1	-4	1	1	1	1	1	1	1	1
↓	↓	↓	↓	↓	↓	↓	↓	↓	↓
-195	-780 max. value for 60 Hz	0	0	1	1	1	1	0	1
↓	↓	↓	↓	↓	↓	↓	↓	↓	↓
-236	-944 max. value for 50 Hz	0	0	0	1	0	1	0	0
↓	↓	↓	↓	↓	↓	↓	↓	↓	↓
-256	-1024 outside central counter ⁽²⁾	0	0	0	0	0	0	0	0

Notes

1. A sign bit, designated A08 and internally set to HIGH, indicates values are always negative.
2. The horizontal PLL does not operate in this condition. The system clock frequency is set to a value fixed by the last update and is within $\pm 7.1\%$ of the nominal frequency.

One Chip Front-end 1 (OCF1)

SAA7110; SAA7110A

16.3.2 SUBADDRESS 01 (DATA BYTE 015 to 008)

Table 12 Horizontal synchronization begin 50 Hz (HSYB)

DECIMAL MULTIPLIER	DELAY TIME (STEP SIZE = 2/LLC)	CONTROL BITS							
		HSYB7	HSYB6	HSYB5	HSYB4	HSYB3	HSYB2	HSYB1	HSYB0
+191	-382	1	0	1	1	1	1	1	1
↓	↓	↓	↓	↓	↓	↓	↓	↓	↓
-64	+128	1	1	0	0	0	0	0	0

16.3.3 SUBADDRESS 02 (DATA BYTE 023 to 016)

Table 13 Horizontal synchronization stop 50 Hz (HSYS)

DECIMAL MULTIPLIER	DELAY TIME (STEP SIZE = 2/LLC)	CONTROL BITS							
		HSYS7	HSYS6	HSYS5	HSYS4	HSYS3	HSYS2	HSYS1	HSYS0
+191	-382	1	0	1	1	1	1	1	1
↓	↓	↓	↓	↓	↓	↓	↓	↓	↓
-64	+128	1	1	0	0	0	0	0	0

16.3.4 SUBADDRESS 03 (DATA BYTE 031 to 024)

Table 14 Horizontal clamping begin 50 Hz (HCLB)

DECIMAL MULTIPLIER	DELAY TIME (STEP SIZE = 2/LLC)	CONTROL BITS							
		HCLB7	HCLB6	HCLB5	HCLB4	HCLB3	HCLB2	HCLB1	HCLB0
+127	-254	0	1	1	1	1	1	1	1
↓	↓	↓	↓	↓	↓	↓	↓	↓	↓
-128	+256	1	0	0	0	0	0	0	0

16.3.5 SUBADDRESS 04 (DATA BYTE 039 to 032)

Table 15 Horizontal clamping stop 50 Hz (HCLS)

DECIMAL MULTIPLIER	DELAY TIME (STEP SIZE = 2/LLC)	CONTROL BITS							
		HCLS7	HCLS6	HCLS5	HCLS4	HCLS3	HCLS2	HCLS1	HCLS0
+127	-254	0	1	1	1	1	1	1	1
↓	↓	↓	↓	↓	↓	↓	↓	↓	↓
-128	+256	1	0	0	0	0	0	0	0

One Chip Front-end 1 (OCF1)

SAA7110; SAA7110A

16.3.6 SUBADDRESS 05 (DATA BYTE 047 to 040)

Table 16 Horizontal synchronization start after PHI1 50 Hz (HPHI)

DECIMAL MULTIPLIER	DELAY TIME (STEP SIZE = 8/LLC)	CONTROL BITS							
		HPHI7	HPHI6	HPHI5	HPHI4	HPHI3	HPHI2	HPHI1	HPHI0
+127	forbidden;	0	1	1	1	1	1	1	1
↓	outside available central counter range	↓	↓	↓	↓	↓	↓	↓	↓
+118		0	1	1	1	0	1	1	0
+117	-32 μ s (max. negative value)	0	1	1	1	0	1	0	1
-118	+31.7 μ s (max. positive value)	1	0	0	0	1	0	1	0
-119	forbidden;	1	0	0	0	1	0	0	1
↓	outside available central counter range	↓	↓	↓	↓	↓	↓	↓	↓
-128		1	0	0	0	0	0	0	0

One Chip Front-end 1 (OCF1)

SAA7110; SAA7110A

16.3.7 SUBADDRESS 06 (DATA BYTE 055 to 048)

Table 17 Luminance control

FUNCTION		CONTROL BITS
Aperture factor (APER); data bits D1 and D0		
0	0	APER1 = 0; APER0 = 0
1	0.25	APER1 = 0; APER0 = 1
2	0.5	APER1 = 1; APER0 = 0
3	1.0	APER1 = 1; APER0 = 1
Corner correction (CORI) \pmLSBs in 8-bit; data bits D3 and D2		
0	0 (OFF)	COR11 = 0; COR10 = 0
1	1	COR11 = 0; COR10 = 1
2	2	COR11 = 1; COR10 = 0
3	3	COR11 = 1; COR10 = 1
Aperture bandpass; centre frequency (BPSS); data bits D4 and D5		
4.6 MHz (50 Hz)	3.8 MHz (60 Hz)	BPSS1 = 0; BPSS0 = 0
4.3 MHz (50 Hz)	3.4 MHz (60 Hz)	BPSS1 = 0; BPSS0 = 1
3.0 MHz (50 Hz)	2.5 MHz (60 Hz)	BPSS1 = 1; BPSS0 = 0
3.2 MHz (50 Hz)	2.7 MHz (60 Hz)	BPSS1 = 1; BPSS0 = 1
Prefilter active (PREF); data bit D6		
Bypassed		PREF = 0
Active		PREF = 1
Chrominance trap bypass (BYPS); data bit D7		
Active	CVBS mode	BYPS = 0
Bypassed	S-Video mode	BYPS = 1

16.3.8 SUBADDRESS 07 (DATA BYTE 063 to 056)

Table 18 Hue phase control HUEC

HUE PHASE (DEGREES)	CONTROL BITS							
	HUEC7	HUEC6	HUEC5	HUEC4	HUEC3	HUEC2	HUEC1	HUEC0
+178.6	0	1	1	1	1	1	1	1
↓	↓	↓	↓	↓	↓	↓	↓	↓
0	0	0	0	0	0	0	0	0
↓	↓	↓	↓	↓	↓	↓	↓	↓
-180	1	0	0	0	0	0	0	0

One Chip Front-end 1 (OCF1)

SAA7110; SAA7110A

16.3.9 SUBADDRESS 08 CONTROL NUMBER 1 (DATA BYTE 071 to 064)

Table 19 Colour killer threshold QUAM (PAL/NTSC)

THRESHOLD (reference is nominal burst amplitude = 0 dB)	CONTROL BITS				
	CKTQ4	CKTQ3	CKTQ2	CKTQ1	CKTQ0
-30 dB	1	1	1	1	1
↓	↓	↓	↓	↓	↓
-24 dB	1	0	0	0	0
↓	↓	↓	↓	↓	↓
-18 dB	0	0	0	0	0

16.3.10 SUBADDRESS 09 CONTROL NUMBER 2 (DATA BYTE 079 to 072)

Table 20 Colour killer threshold SECAM

THRESHOLD (reference is nominal burst amplitude = 0 dB)	CONTROL BITS				
	CKTS4	CKTS3	CKTS2	CKTS1	CKTS0
-30 dB	1	1	1	1	1
↓	↓	↓	↓	↓	↓
-24 dB	1	0	0	0	0
↓	↓	↓	↓	↓	↓
-18 dB	0	0	0	0	0

16.3.11 SUBADDRESS 0A (DATA BYTE 087 to 080)

Table 21 PAL switch sensitivity

SENSITIVITY	CONTROL BITS							
	PLSE7	PLSE6	PLSE5	PLSE4	PLSE3	PLSE2	PLSE1	PLSE0
Low	1	1	1	1	1	1	1	1
Medium	1	0	0	0	0	0	0	0
High ⁽¹⁾	0	0	0	0	0	0	0	0

Note

1. Sensitivity HIGH means immediate sequence correction.

16.3.12 SUBADDRESS 0B (DATA BYTE 095 to 088)

Table 22 SECAM switch sensitivity

SENSITIVITY	CONTROL BITS							
	SESE7	SESE6	SESE5	SESE4	SESE3	SESE2	SESE1	SESE0
Low	1	1	1	1	1	1	1	1
Medium	1	0	0	0	0	0	0	0
High ⁽¹⁾	0	0	0	0	0	0	0	0

Note

1. Sensitivity HIGH means immediate sequence correction.

One Chip Front-end 1 (OCF1)

SAA7110; SAA7110A

16.3.13 SUBADDRESS 0C (DATA BYTE 103 to 096)

Table 23 Gain control chrominance

FUNCTION	CONTROL BITS
AGC loop filter (LFIS); data bits D6 and D5	
Slow time constant	LFIS1 = 0; LFIS0 = 0
Medium time constant	LFIS1 = 0; LFIS0 = 1
Fast time constant	LFIS1 = 1; LFIS0 = 0
Actual chrominance gain frozen	LFIS1 = 1; LFIS0 = 1
Colour on (COLO); data bit D7	
Automatic colour killer	COLO = 0
Colour forced on	COLO = 1

16.3.14 SUBADDRESS 0D (DATA BYTE 111 to 104)

Table 24 Standard/mode control

FUNCTION	CONTROL BITS
SECAM mode bit (SECS); data bit D0	
Other standards	SECS = 0
SECAM mode	SECS = 1
Status byte select (SSTB); data bit D1	
Status byte = 0 (see transmitter)	SSTB = 0
Status byte = 1 (see transmitter)	SSTB = 1
HREF position select (HRMV); data bit D2	
HREF position as SAA7191 (8 LLC2 later)	HRMV = 0
HREF normal position	HRMV = 1
Real time outputs mode select (RTSE); data bit D3	
PLIN switched to output pin 39 ODD switched to output pin 40	RTSE = 0
HL switched to output pin 39 VL switched to output pin 40	RTSE = 1
TV/VCR mode select (VTRC); data bit D7	
TV mode	VTRC = 0
VTR mode	VTRC = 1

One Chip Front-end 1 (OCF1)

SAA7110; SAA7110A

16.3.15 SUBADDRESS 0E (DATA BYTE 119 to 112)

Table 25 I/O and clock control

FUNCTION	CONTROL BITS
General purpose switch (GPSW); data bit D0	
Switches directly pin 64 GPSW (application dependent); VBLKA = 0	GPSW = 0
	GPSW = 1
Select chrominance input (CHRS); data bit D2	
Controlled by BYPS (subaddress 06) normal position	CHRS = 0
Digital chrominance input switched to second input channel (see Fig.20)	CHRS = 1
Output enable YUV-data (OEYC); data bit D3	
YUV bus high impedance/input	OEYC = 0
Output YUV-bus active	OEYC = 1
Output enable horizontal/vertical synchronization (OEHV); data bit D4	
HS, HREF and VS high impedance/inputs	OEHV = 0
Output HS, HREF and VS active	OEHV = 1
Horizontal PLL clock (HPLL); data bit D7	
PLL closed	HPLL = 0
PLL open, horizontal frequency fixed	HPLL = 1

16.3.16 SUBADDRESS 0F (DATA BYTE 127 to 120)

Table 26 Control number 1

FUNCTION	CONTROL BITS
Luminance delay compensation; steps in 2/LLC (YDEL); data bits D2, D1 and D0	
0 steps	YDEL2 = 0; YDEL1 = 0; YDEL0 = 0
3 steps	YDEL2 = 0; YDEL1 = 1; YDEL0 = 1
-4 steps	YDEL2 = 1; YDEL1 = 0 YDEL1 = 0
Enable or disable of sync and clamp pulses; HSY and HCL (SCEN); data bit D4	
Disable sync and clamp (set to HIGH)	SCEN = 0
Enable sync and clamp	SCEN = 1
SECAM cross colour reduction (SXCR); data bit D5	
Reduction off	SXCR = 0
Reduction on	SXCR = 1
Field selection (FSEL); data bit D6	
50 Hz, 625 lines	FSEL = 0
60 Hz, 525 lines	FSEL = 1
Automatic field detection(AUFD); data bit D7	
Field state directly controlled via FSEL	AUFD = 0
Automatic field detection	AUFD = 1

One Chip Front-end 1 (OCF1)

SAA7110; SAA7110A

16.3.17 SUBADDRESS 10 (DATA BYTE 135 to 128)

Table 27 Control number 2

FUNCTION	CONTROL BITS
Vertical noise reduction (VNOI); data bits D1 and D0	
Normal mode	VNOI1 = 0; VNOI0 = 0
Search mode	VNOI1 = 0; VNOI0 = 1
Free running mode	VNOI1 = 1; VNOI0 = 0
Vertical noise reduction bypassed	VNOI1 = 1; VNOI0 = 1
HREF select HRFS (HRFS); data bit D2	
HREF matched to YUV output	HRFS = 0
HREF matched to CVBS input	HRFS = 1

16.3.18 SUBADDRESS 11 (DATA BYTE 143 to 136)

Table 28 Chrominance gain reference value

REFERENCE VALUE	CONTROL BITS							
	CHCV7	CHCV6	CHCV5	CHCV4	CHCV3	CHCV2	CHCV1	CHCV0
Maximum	1	1	1	1	1	1	1	1
CCIR-level for PAL	0	1	0	1	1	0	0	1
CCIR-level for NTSC	0	0	1	0	1	1	0	0
Minimum	0	0	0	0	0	0	0	0

16.3.19 SUBADDRESS 12 (DATA BYTE 150 to 144)

Table 29 Chrominance saturation control

GAIN	CONTROL BITS							
	SATN7	SATN6	SATN5	SATN4	SATN3	SATN2	SATN1	SATN0
1.999 Maximum	0	1	1	1	1	1	1	1
1 CCIR-level	0	1	0	0	0	0	0	0
0 colour off	0	0	0	0	0	0	0	0
-1 inverse chrominance	1	1	0	0	0	0	0	0
-2 inverse chrominance	1	0	0	0	0	0	0	0

One Chip Front-end 1 (OCF1)

SAA7110; SAA7110A

16.3.20 SUBADDRESS 13 (DATA BYTE 158 to 152)

Table 30 Luminance contrast control

GAIN	CONTROL BITS							
	CONT7	CONT6	CONT5	CONT4	CONT3	CONT2	CONT1	CONT0
1.999 Maximum	0	1	1	1	1	1	1	1
70 CCIR-level	0	1	0	0	0	1	1	0
1	0	1	0	0	0	0	0	0
0 luminance off	0	0	0	0	0	0	0	0
-1 inverse luminance	1	1	0	0	0	0	0	0
-2 inverse luminance	1	0	0	0	0	0	0	0

16.3.21 SUBADDRESS 14 (DATA BYTE 167 to 160)

Table 31 Horizontal synchronization begin 60 Hz (HS6B)

DECIMAL MULTIPLIER	DELAY TIME (step size = 2/LLC)	CONTROL BITS							
		HS6B7	HS6B6	HS6B5	HS6B4	HS6B3	HS6B2	HS6B1	HS6B0
+191	-382	1	0	1	1	1	1	1	1
↓	↓	↓	↓	↓	↓	↓	↓	↓	↓
-64	+128	1	1	0	0	0	0	0	0

16.3.22 SUBADDRESS 15 (DATA BYTE 175 to 168)

Table 32 Horizontal synchronization stop 60 Hz (HS6S)

DECIMAL MULTIPLIER	DELAY TIME (step size = 2/LLC)	CONTROL BITS							
		HS6S7	HS6S6	HS6S5	HS6S4	HS6S3	HS6S2	HS6S1	HS6S0
+191	-382	1	0	1	1	1	1	1	1
↓	↓	↓	↓	↓	↓	↓	↓	↓	↓
-64	+128	1	1	0	0	0	0	0	0

16.3.23 SUBADDRESS 16 (DATA BYTE 183 to 176)

Table 33 Horizontal clamping begin 60 Hz (HC6B)

DECIMAL MULTIPLIER	DELAY TIME (step size = 2/LLC)	CONTROL BITS							
		HC6B7	HC6B6	HC6B5	HC6B4	HC6B3	HC6B2	HC6B1	HC6B0
+127	-254	0	1	1	1	1	1	1	1
↓	↓	↓	↓	↓	↓	↓	↓	↓	↓
-128	+256	1	0	0	0	0	0	0	0

One Chip Front-end 1 (OCF1)

SAA7110; SAA7110A

16.3.24 SUBADDRESS 17 (DATA BYTE 191 to 184)

Table 34 Horizontal clamping stop 60 Hz (HC6S)

DECIMAL MULTIPLIER	DELAY TIME (step size = 2/LLC)	CONTROL BITS							
		HC6S7	HC6S6	HC6S5	HC6S4	HC6S3	HC6S2	HC6S1	HC6S0
+127	-254	0	1	1	1	1	1	1	1
↓	↓	↓	↓	↓	↓	↓	↓	↓	↓
-128	+256	1	0	0	0	0	0	0	0

16.3.25 SUBADDRESS 18 (DATA BYTE 199 to 192)

Table 35 Horizontal synchronization start after PHI1 60 Hz (HP6I)

DECIMAL MULTIPLIER	DELAY TIME (step size = 8/LLC)	CONTROL BITS							
		HP6I7	HP6I6	HP6I5	HP6I4	HP6I3	HP6I2	HP6I1	HP6I0
+127	forbidden; outside available central counter range	0	1	1	1	1	1	1	1
↓		↓	↓	↓	↓	↓	↓	↓	↓
+98		0	1	1	0	0	0	1	0
+97	-32 μ s (max. negative value)	0	1	1	0	0	0	0	1
-97	+31.7 μ s (max. positive value)	1	0	0	1	1	1	1	1
-98	forbidden; outside available central counter range	1	0	0	1	1	1	1	0
↓		↓	↓	↓	↓	↓	↓	↓	↓
-128		1	0	0	0	0	0	0	0

16.3.26 SUBADDRESS 19 (DATA BYTE 207 to 200)

Table 36 Luminance brightness control

OFFSET	CONTROL BITS							
	BRIG7	BRIG6	BRIG5	BRIG4	BRIG3	BRIG2	BRIG1	BRIG0
255 (bright)	1	1	1	1	1	1	1	1
139 (CCIR-level)	1	0	0	0	1	0	1	1
128	1	0	0	0	0	0	0	0
0 (dark)	0	0	0	0	0	0	0	0

One Chip Front-end 1 (OCF1)

SAA7110; SAA7110A

16.4 I²C-bus detail (continued)

DUAD slave receiver (SU 20H to 32H).

16.4.1 SUBADDRESS 20 (DATA BYTE 007 to 000)

Table 37 Analog control #1

FUNCTION	CONTROL BITS
Analog input select 2 (AINS2); data bit D0	
Analog input AI22 selected	AINS2 = 0
Analog input AI21 selected	AINS2 = 1
Analog input select 3 (AINS3); data bit D1	
Analog input AI32 selected	AINS3 = 0
Analog input AI31 selected	AINS3 = 1
Analog input select 4 (AINS4); data bit D2	
Analog input AI42 selected	AINS4 = 0
Analog input AI41 selected	AIND4 = 1
Analog function select (FUSE); data bits D4 and D3	
Amplifier plus anti-alias filter bypassed	FUSE1 = 0; FUSE0 = 0
	FUSE1 = 0; FUSE0 = 1
Amplifier active	FUSE1 = 1; FUSE0 = 0
Amplifier plus anti-alias filter active	FUSE1 = 1; FUSE0 = 1
Analog input disable 2 (AIND2); data bit D5	
Analog inputs 2 enabled	AIND2 = 0
Analog inputs 2 disabled	AIND2 = 1
Analog input disable 3 (AIND3); data bit D6	
Analog inputs 3 enabled	AIND3 = 0
Analog inputs 3 disabled	AIND3 = 1
Analog input disable 4 (AIND4); data bit D7	
Analog inputs 4 enabled	AIND4 = 0
Analog inputs 4 disabled	AIND4 = 1

One Chip Front-end 1 (OCF1)

SAA7110; SAA7110A

16.4.2 SUBADDRESS 21 (DATA BYTE 015 to 008)

Table 38 Analog control #2

FUNCTION	CONTROL BITS
Reference select channel 2 (REFS2); data bit D0	
Automatic clamping active	REFS2 = 0
Reference level selected	REFS2 = 1
Reference select channel 3 (REFS3); data bit D1	
Automatic clamping active	REFS3 = 0
Reference level selected	REFS3 = 1
Reference select channel 4 (REFS4); data bit D2	
Automatic clamping active	REFS4 = 0
Reference level selected	REFS4 = 1
MUXC select channel 24 (MS24); data bit D3	
Analog MUX2 controlled by MX24	MS24 = 0
Analog MUX2 controlled by MUXC	MS24 = 1
Analog MUX2 control (MX24); data bits D5 and D4	
Adder mode	MX241 = 0; MX240 = 0
Channel 2 on; channel 4 off	MX241 = 0; MX240 = 1
Channel 2 off; channel 4 on	MX241 = 1; MX240 = 0
Both channels off	MX241 = 1; MX240 = 1
MUXC select channel 34 (MS34); data bit D6	
Analog MUX3 controlled by MX34	MS34 = 0
Analog MUX3 controlled by MUXC	MS34 = 1
Vertical blanking control off (VBCO); data bit D7	
Vertical blanking on	VBCO = 0
Vertical blanking off	VBCO = 1

One Chip Front-end 1 (OCF1)

SAA7110; SAA7110A

16.4.3 SUBADDRESS 22 (DATA BYTE 023 to 016)

Table 39 Mixer control #1

FUNCTION	CONTROL BITS
Analog MUX3 control (MX34); data bits D1 and D0	
Adder mode	MX341 = 0; MX340 = 0
Channel 3 on; channel 4 off	MX341 = 0; MX340 = 1
Channel 3 off; channel 4 on	MX341 = 1; MX340 = 0
Both channels off	MX341 = 1; MX340 = 1
Clamping function test (CLTS); data bit D2	
Normal clamping mode	CLTS = 0
CLAA _n and CLAU _n adjusted via CLL32 value for testing (do not use)	CLTS = 1
Fast digital multiplexing channel 2/3 active (MUYC); data bit D3	
Normal mode on CHR channel	MUYC = 0
Multiplex mode on CHR channel for test purposes only (do not use)	MUYC = 1
Luminance select (YSEL); data bit D4	
ADC 2 to CVBS	YSEL = 0
ADC 3 to CVBS	YSEL = 1
Chrominance select (CSEL); data bit D5	
ADC 3 to CHR (MUXC not inverse; MUYC = 1)	CSEL = 0
ADC 2 to CHR (MUXC inverse; MUYC = 1)	CSEL = 1
Automatic gain control (GACO); data bits D7 and D6	
Automatic gain control off	GACO1 = 0; GACO0 = 0
Automatic gain control channel 2	GACO1 = 0; GACO0 = 1
Automatic gain control channel 3	GACO1 = 1; GACO0 = 0
Automatic gain control channel 4	GACO1 = 1; GACO0 = 1

16.4.4 SUBADDRESS 23 (DATA BYTE 031 to 024)

Table 40 Clamping level control 21 CLL21

DECIMAL CLAMP LEVEL	CONTROL BITS							
	CLL217	CLL216	CLL215	CLL214	CLL213	CLL212	CLL211	CLL210
1	0	0	0	0	0	0	0	1
↓	↓	↓	↓	↓	↓	↓	↓	↓
64	0	1	0	0	0	0	0	0
↓	↓	↓	↓	↓	↓	↓	↓	↓
128	1	0	0	0	0	0	0	0
↓	↓	↓	↓	↓	↓	↓	↓	↓
254	1	1	1	1	1	1	1	0

One Chip Front-end 1 (OCF1)

SAA7110; SAA7110A

16.4.5 SUBADDRESS 24 (DATA BYTE 039 to 032)

Table 41 Clamping level control 22 CLL22

DECIMAL CLAMP LEVEL	CONTROL BITS							
	CLL227	CLL226	CLL225	CLL224	CLL223	CLL222	CLL221	CLL220
1	0	0	0	0	0	0	0	1
↓	↓	↓	↓	↓	↓	↓	↓	↓
64	0	1	0	0	0	0	0	0
↓	↓	↓	↓	↓	↓	↓	↓	↓
128	1	0	0	0	0	0	0	0
↓	↓	↓	↓	↓	↓	↓	↓	↓
254	1	1	1	1	1	1	1	0

16.4.6 SUBADDRESS 25 (DATA BYTE 047 to 040)

Table 42 Clamping level control 31 CLL31

DECIMAL CLAMP LEVEL	CONTROL BITS							
	CLL317	CLL316	CLL315	CLL314	CLL313	CLL312	CLL311	CLL310
1	0	0	0	0	0	0	0	1
↓	↓	↓	↓	↓	↓	↓	↓	↓
64	0	1	0	0	0	0	0	0
↓	↓	↓	↓	↓	↓	↓	↓	↓
128	1	0	0	0	0	0	0	0
↓	↓	↓	↓	↓	↓	↓	↓	↓
254	1	1	1	1	1	1	1	0

16.4.7 SUBADDRESS 26 (DATA BYTE 055 to 048)

Table 43 Clamping level control 32 CLL32

DECIMAL CLAMP LEVEL	CONTROL BITS							
	CLL327	CLL326	CLL325	CLL324	CLL323	CLL322	CLL321	CLL320
1	0	0	0	0	0	0	0	1
↓	↓	↓	↓	↓	↓	↓	↓	↓
64	0	1	0	0	0	0	0	0
↓	↓	↓	↓	↓	↓	↓	↓	↓
128	1	0	0	0	0	0	0	0
↓	↓	↓	↓	↓	↓	↓	↓	↓
254	1	1	1	1	1	1	1	0

One Chip Front-end 1 (OCF1)

SAA7110; SAA7110A

16.4.8 SUBADDRESS 27 (DATA BYTE 063 to 056); GAIN CONTROL ANALOG #1

Table 44 Static gain control channel 2 (GAI2); data bits D5 to D0

DECIMAL MULTIPLIER	GAIN (step size = 0.19 dB)	CONTROL BITS					
		GAI25	GAI24	GAI23	GAI22	GAI21	GAI20
0	-2.82 dB	0	0	0	0	0	0
↓	↓	↓	↓	↓	↓	↓	↓
15	0 dB	0	0	1	1	1	1
↓	↓	↓	↓	↓	↓	↓	↓
31	3 dB	0	1	1	1	1	1
↓	↓	↓	↓	↓	↓	↓	↓
47	6 dB	1	0	1	1	1	1
↓	↓	↓	↓	↓	↓	↓	↓
63	9 dB	1	1	1	1	1	1

Table 45 Gain mode select (GASL); data bit D6

FUNCTION	CONTROL BIT GASL
Difference value integration	0
Fix value integration	1

Table 46 Automatic control integration (HOLD); data bit D7

FUNCTION	CONTROL BIT HOLD
AGC active	0
AGC integration hold (freeze)	1

16.4.9 SUBADDRESS 28 (DATA BYTE 071 to 064)

Table 47 White peak control WIPE

DECIMAL WHITE PEAK LEVEL	CONTROL BITS							
	WIPE7	WIPE6	WIPE5	WIPE4	WIPE3	WIPE2	WIPE1	WIPE0
128	1	0	0	0	0	0	0	0
↓	↓	↓	↓	↓	↓	↓	↓	↓
254	1	1	1	1	1	1	1	0
255 (white peak control off)	1	1	1	1	1	1	1	1

16.4.10 SUBADDRESS 29 (DATA BYTE 079 to 072)

Table 48 Sync bottom control SBOT

DECIMAL SYNC BOTTOM LEVEL	CONTROL BITS							
	SBOT7	SBOT6	SBOT5	SBOT4	SBOT3	SBOT2	SBOT1	SBOT0
1	0	0	0	0	0	0	0	1
↓	↓	↓	↓	↓	↓	↓	↓	↓
254	1	1	1	1	1	1	1	0

One Chip Front-end 1 (OCF1)

SAA7110; SAA7110A

16.4.11 SUBADDRESS 2A (DATA BYTE 087 to 080); GAIN CONTROL ANALOG #2

Table 49 Static gain control channel 3 (GAI3); data bits D5 to D0

DECIMAL MULTIPLIER	GAIN (step size = 0.19 dB)	CONTROL BITS					
		GAI35	GAI34	GAI33	GAI32	GAI31	GAI30
0	-2.82 dB	0	0	0	0	0	0
↓	↓	↓	↓	↓	↓	↓	↓
15	0 dB	0	0	1	1	1	1
↓	↓	↓	↓	↓	↓	↓	↓
31	3 dB	0	1	1	1	1	1
↓	↓	↓	↓	↓	↓	↓	↓
47	6 dB	1	0	1	1	1	1
↓	↓	↓	↓	↓	↓	↓	↓
63	9 dB	1	1	1	1	1	1

Table 50 Integration factor white peak (IWIP); data bits D7 and D6

FUNCTION	CONTROL BITS
Fast selection	IWIP1 = 0; IWIP0 = 0
	IWIP1 = 0; IWIP0 = 1
	IWIP1 = 1; IWIP0 = 0
Slow selection	IWIP1 = 1; IWIP0 = 1

16.4.12 SUBADDRESS 2B (DATA BYTE 095 to 088); GAIN CONTROL ANALOG #3

Table 51 Static gain control channel 4 (GAI4); data bits D5 to D0

DECIMAL MULTIPLIER	GAIN (step size = 0.19 dB)	CONTROL BITS					
		GAI45	GAI44	GAI43	GAI42	GAI41	GAI40
0	-2.82 dB	0	0	0	0	0	0
↓	↓	↓	↓	↓	↓	↓	↓
15	0 dB	0	0	1	1	1	1
↓	↓	↓	↓	↓	↓	↓	↓
31	3 dB	0	1	1	1	1	1
↓	↓	↓	↓	↓	↓	↓	↓
47	6 dB	1	0	1	1	1	1
↓	↓	↓	↓	↓	↓	↓	↓
63	9 dB	1	1	1	1	1	1

Table 52 Integration factor normal gain (IGAI); data bits D7 and D6

FUNCTION	CONTROL BITS
Slow selection	IGAI1 = 0; IGAI0 = 0
	IGAI1 = 0; IGAI0 = 1
	IGAI1 = 1; IGAI0 = 0
Fast selection	IGAI1 = 1; IGAI0 = 1

One Chip Front-end 1 (OCF1)

SAA7110; SAA7110A

16.4.13 SUBADDRESS 2C (DATA BYTE 103 to 096)

Table 53 Mixer control #2

FUNCTION	CONTROL BITS
Two's complement channel 2 (TWO2); data bit D0	
Unipolar	TWO2 = 0
Two's complement (normal mode)	TWO2 = 1
Two's complement channel 3 (TWO3); data bit D1	
Unipolar	TWO3 = 0
Two's complement (normal mode)	TWO3 = 1
Clamping level select channel 2 (CLS2); data bit D4	
CLL21 active	CLS2 = 0
CLL22 active	CLS2 = 1
Clamping level select channel 3 (CLS3); data bit D5	
CLL31 active	CLS3 = 0
CLL32 active	CLS3 = 1
Clamping level select channel 4 (CLS4); data bit D7	
CLL2n active	CLS4 = 0
CLL3n active	CLS4 = 1

16.4.14 SUBADDRESS 2D (DATA BYTE 111 to 104)

Table 54 Integration value gain (IVAL)

DECIMAL INTEGRATION VALUE GAIN	CONTROL BITS							
	IVAL7	IVAL6	IVAL5	IVAL4	IVAL3	IVAL2	IVAL1	IVAL0
1	0	0	0	0	0	0	0	1
↓	↓	↓	↓	↓	↓	↓	↓	↓
255	1	1	1	1	1	1	1	1

16.4.15 SUBADDRESS 2E (DATA BYTE 119 to 112)

Table 55 Blanking pulse VBLK-set (VBPS)

DECIMAL MULTIPLIER	SET LINE NUMBER (step size = 2)	CONTROL BITS							
		VBPS7	VBPS6	VBPS5	VBPS4	VBPS3	VBPS2	VBPS1	VBPS0
0	0 after rising edge of VS	0	0	0	0	0	0	0	0
↓	↓	↓	↓	↓	↓	↓	↓	↓	↓
131 ⁽¹⁾	262 after rising edge of VS	1	0	0	0	0	0	1	1
↓	↓	↓	↓	↓	↓	↓	↓	↓	↓
156 ⁽²⁾	312 after rising edge of VS	1	0	0	1	1	1	0	0

Notes

1. Maximum for 60 Hz.
2. Maximum for 50 Hz.

One Chip Front-end 1 (OCF1)

SAA7110; SAA7110A

16.4.16 SUBADDRESS 2F (DATA BYTE 127 to 120)

Table 56 Blanking pulse VBLK-reset (VBPR)

DECIMAL MULTIPLIER	RESET LINE NUMBER (step size = 2)	CONTROL BITS							
		VBPR7	VBPR6	VBPR5	VBPR4	VBPR3	VBPR2	VBPR1	VBPR0
0	0 after rising edge of VS	0	0	0	0	0	0	0	0
↓	↓	↓	↓	↓	↓	↓	↓	↓	↓
131 ⁽¹⁾	262 after rising edge of VS	1	0	0	0	0	0	1	1
↓	↓	↓	↓	↓	↓	↓	↓	↓	↓
156 ⁽²⁾	312 after rising edge of VS	1	0	0	1	1	1	0	0

Notes

1. Maximum for 60 Hz.
2. Maximum for 50 Hz.

16.4.17 SUBADDRESS 30 (DATA BYTE 135 to 128)

Table 57 ADCs gain control

FUNCTION	CONTROL BITS
Fix gain ADC channel 2 (GAD2); data bits D1 and D0	
0 dB	GAD21 = 0; GAD20 = 0
0.05 dB	GAD21 = 0; GAD20 = 1
0.10 dB	GAD21 = 1; GAD20 = 0
0.15 dB	GAD21 = 1; GAD20 = 1
Gain ADC select channel 2 (GAS2); data bit D2	
Fix gain via I ² C-bus GAD2	GAS2 = 0
Automatic gain via loop	GAS2 = 1
Fix gain ADC channel 3 (GAD3); data bits D4 and D3	
0 dB	GAD31 = 0; GAD30 = 0
0.05 dB	GAD31 = 0; GAD30 = 1
0.10 dB	GAD31 = 1; GAD30 = 0
0.15 dB	GAD31 = 1; GAD30 = 1
Gain ADC select channel 3 (GAS3); data bit D5	
Fix gain via I ² C-bus GAD3	GAS3 = 0
Automatic gain via loop	GAS3 = 1
White peak mode select (WISL); data bit D6	
Difference value integration	WISL = 0
Fix value integration	WISL = 1

One Chip Front-end 1 (OCF1)

SAA7110; SAA7110A

16.4.18 SUBADDRESS 31 (DATA BYTE 143 to 136)

Table 58 Mixer control #3

FUNCTION	CONTROL BITS
Pulses I/O control (PULIO); data bit D0	
HCL and HSY to input pins	PULIO = 0
HCL and HSY to output pins	PULIO = 1
Pin function switch (VBLKA); data bit D1	
GPSW active (normal)	VBLKA = 0
VBLK test output active	VBLKA = 1
DMSD-SQP bypassed (SQPB); data bit D3	
DMSD data to YUV output	SQPB = 0
A/D data to YUV output for test purposes only (do not use)	SQPB = 1
White peak slow up integration enable (WRSE); data bit D4	
Hold in white peak mode	WRSE = 0
Slow up integration with 1 value in H or V (dependent on WIRS)	WRSE = 1
White peak slow up integration select (WIRS); data bit D5	
Slow up integration with 1 value per line	WRIS = 0
Slow up integration with 1 value per field	WRIS = 1
Analog test select (AOSL); data bits D7 and D6	
AOUT connected to ground	AOSL1 = 0; AOSL0 = 0
AOUT connected to input AD2	AOSL1 = 0; AOSL0 = 0
AOUT connected to input AD3	AOSL1 = 1; AOSL0 = 1
AOUT connected to channel 4	AOSL1 = 1; AOSL0 = 1

16.4.19 SUBADDRESS 32 (DATA BYTE 151 to 144)

Table 59 Integration value white peak (WVAL)

DECIMAL INTEGRATION VALUE WHITE PEAK	CONTROL BITS							
	WVAL7	WVAL6	WVAL5	WVAL4	WVAL3	WVAL2	WVAL1	WVAL0
1	0	0	0	0	0	0	0	1
↓	↓	↓	↓	↓	↓	↓	↓	↓
127 (max.)	0	1	1	1	1	1	1	1

One Chip Front-end 1 (OCF1)

SAA7110; SAA7110A

16.4.20 SUBADDRESS 33 (DATA BYTE 159 to 152)

Table 60 Mixer control #4

FUNCTION	CONTROL BITS
Clock select AD2 (CAD2); data bit D2	
LLC for test purposes only (do not use)	CAD2 = 0
LLC/2	CAD2 = 1
Clock select AD3 (CAD3); data bit D3	
LLC for test purposes only (do not use)	CAD3 = 0
LLC/2	CAD3 = 1
Change sign bit UV data (CHSB); data bit D5	
UV output unipolar	CHSB = 0
UV output two's complement	CHSB = 1
Output format select (OFTS); data bit D7	
4 : 1 : 1 format	OFTS = 0
4 : 2 : 2 format	OFTS = 1

16.4.21 SUBADDRESS 34 (DATA BYTE 167 to 160)

Table 61 Gain update level (GUDL; data bits D5 to D0)

DECIMAL	HYSTERESIS FOR 8-BIT GAIN	UPDATE NEW GAIN - OLD GAIN	CONTROL BITS					
			GUDL5	GUDL4	GUDL3	GUDL2	GUDL1	GUDL0
0	0 LSB	>0	0	0	0	0	0	0
↓	↓	↓	↓	↓	↓	↓	↓	↓
7	±7 LSB	>7	0	0	0	1	1	1
↓	↓	↓	↓	↓	↓	↓	↓	↓
>31	off	always	1	X	X	X	X	X

Table 62 MUXC phase delay (MUD2); data bits D7 and D6

FUNCTION	CONTROL BIT MUD
No phase delay	MUD2 = 0; MUD1 = 0
1 LLC cycle phase delay for CLAA path	MUD2 = 0; MUD1 = 1
2 LLC cycle phase delay for CLAA path	MUD2 = 1; MUD1 = 0
3 LLC cycle phase delay for CLAA path	MUD2 = 1; MUD1 = 1

One Chip Front-end 1 (OCF1)

SAA7110; SAA7110A

17 SOURCE SELECTION MANAGEMENT

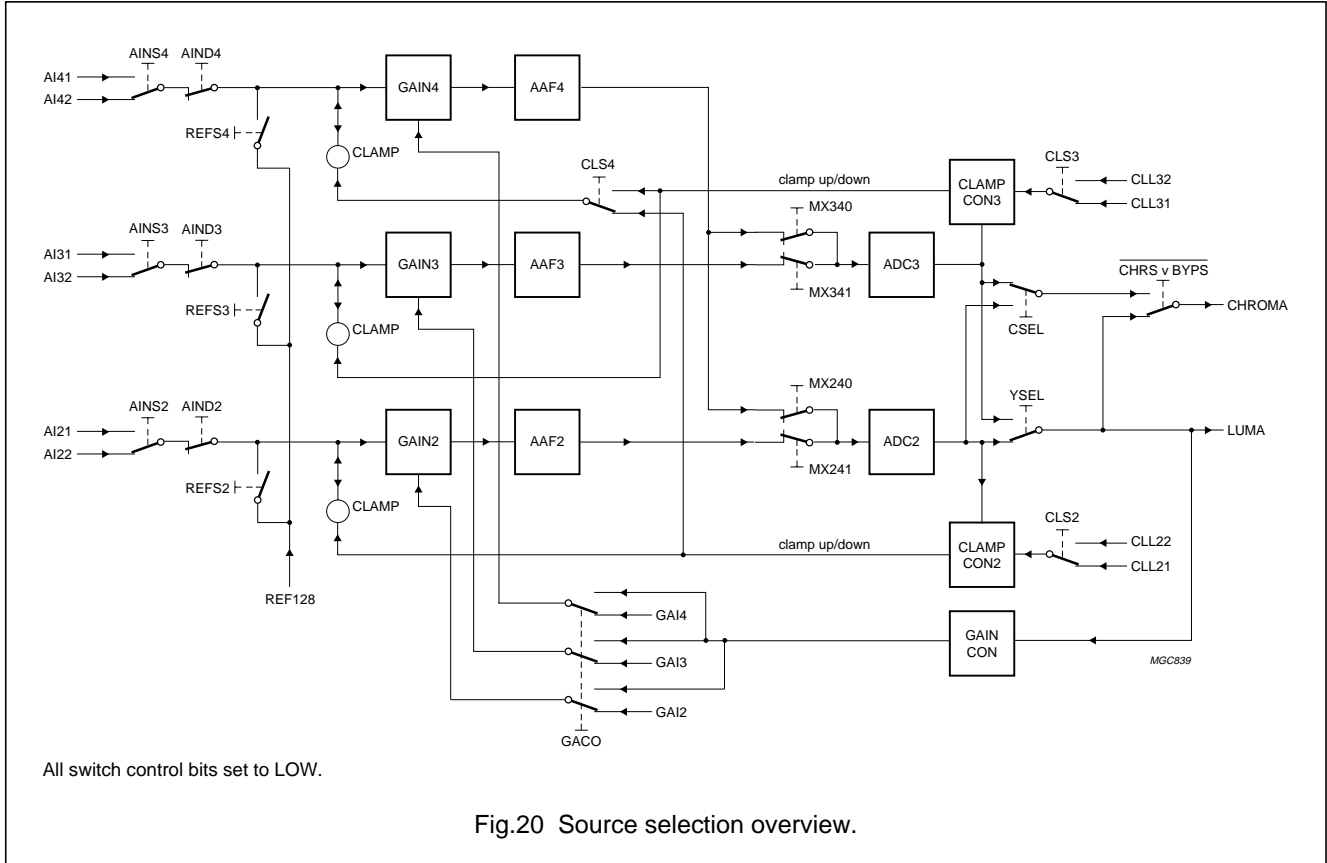
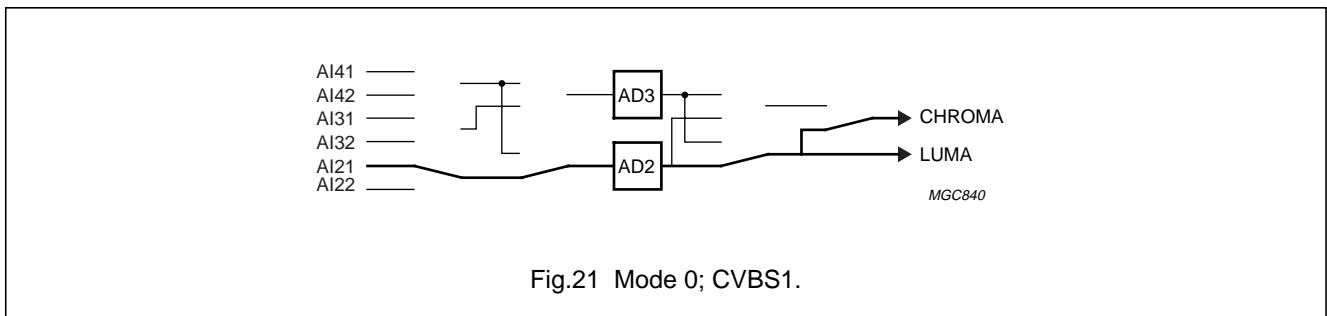

Table 63 Source selection management examples

INPUT	EXAMPLE 1		EXAMPLE 2		EXAMPLE 3		EXAMPLE 4	
	SIGNAL	MODE	SIGNAL	MODE	SIGNAL	MODE	SIGNAL	MODE
AIN21	CVBS1	0	CVBS1	0	Y1	6	Y1	6
AIN22	CVBS2	1	C2	7	C2	7	CVBS2	1
AIN31	CVBS3	2	Y2	7	Y2	7	CVBS3	2
AIN32	CVBS4	3	C3	8	C3	8	CVBS4	3
AIN41	CVBS5	4	Y3	8	Y3	8	CVBS5	4
AIN42	CVBS6	5	CVBS6	5	C1	6	C1	6



One Chip Front-end 1 (OCF1)

SAA7110; SAA7110A

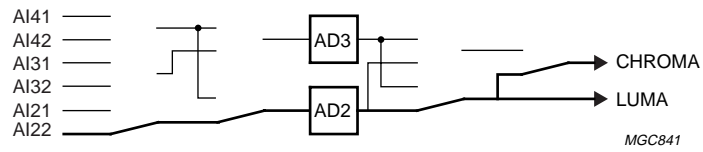

Fig.22 Mode 1; CVBS2.

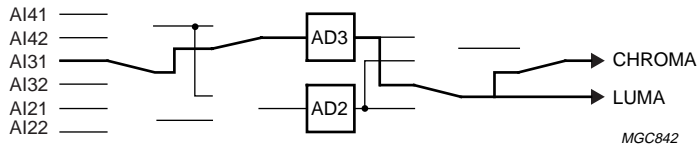

Fig.23 Mode 2; CVBS3.

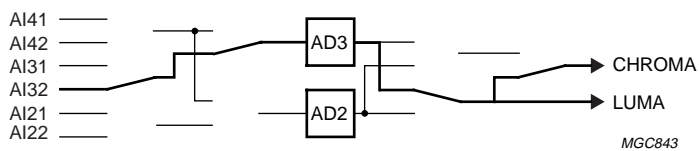

Fig.24 Mode 3; CVBS4.

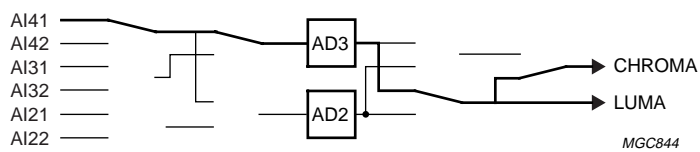
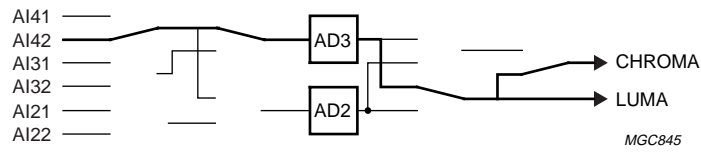

Fig.25 Mode 4; CVBS5.

One Chip Front-end 1 (OCF1)

SAA7110; SAA7110A



MGC845

Fig.26 Mode 5; CVBS6.

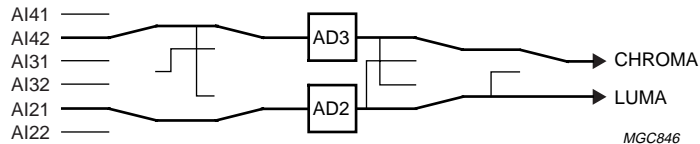

MGC846

Fig.27 Mode 6; Y1 + C1.

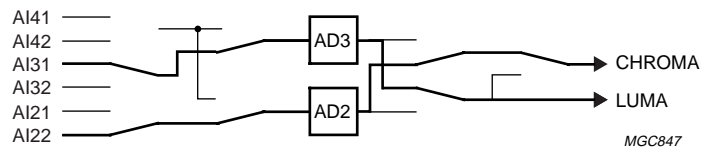

MGC847

Fig.28 Mode 7; Y2 + C2.

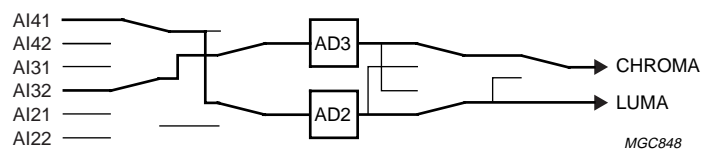

MGC848

Fig.29 Mode 8; Y3 + C3.

One Chip Front-end 1 (OCF1)

SAA7110; SAA7110A

Table 64 I²C-bus control

CONTROL INPUT ⁽¹⁾	MODE									
	0	1	2	3	4	5	6	7	8	9
Subaddress 20										
AIND4	1	1	1	1	0	0	0	1	0	–
AIND3	1	1	0	0	1	1	1	0	0	–
AIND2	0	0	1	1	1	1	0	0	1	–
FUSE1	1	–	–	–	–	–	–	–	–	–
FUSE0	1	–	–	–	–	–	–	–	–	–
AINS4	X	X	X	X	1	0	0	X	1	–
AINS3	X	X	1	0	X	X	0	1	0	–
AINS2	1	0	X	X	X	X	1	0	X	–
Subaddress 21										
VBCO	0	–	–	–	–	–	–	–	–	–
MS34	0	–	–	–	–	–	–	–	–	–
MX241	0	0	X	X	X	X	0	0	1	–
MX240	0	0	X	X	X	X	0	0	1	–
MS24	0	–	–	–	–	–	–	–	–	–
REFS4	1	1	1	1	0	0	0	1	0	–
REFS3	1	1	0	0	1	1	1	0	0	–
REFS2	0	0	1	1	1	1	0	0	1	–
Subaddress 22										
GACO1	0	0	1	1	1	1	0	1	1	–
GACO0	1	1	0	0	1	1	1	0	1	–
CSEL	X	X	X	X	X	X	0	1	0	–
YSEL	0	0	1	1	1	1	0	1	0	–
MUYC	0	–	–	–	–	–	–	–	–	0
CLTS	0	–	–	–	–	–	–	–	–	0
MX341	X	X	0	0	1	1	1	0	0	–
MX340	X	X	1	1	0	0	0	1	1	–
Subaddress 2C										
CLS4	X	X	X	X	1	1	1	X	0	–
GABL	0	–	–	–	–	–	–	–	–	–
CLS3	X	X	0	0	0	0	1	0	1	–
CLS2	0	0	X	X	X	X	0	1	X	–
4LSB	0011	–	–	–	–	–	–	–	–	0011
BYPS	0	0	0	0	0	0	1	1	1	–
Subaddresses SU										
20H	D9H	D8H	BAH	B8H	7CH	78H	59H	9AH	3CH	–
21H	16H	16H	05H	05H	03H	03H	12H	14H	21H	–

One Chip Front-end 1 (OCF1)

SAA7110; SAA7110A

CONTROL INPUT ⁽¹⁾	MODE										
	0	1	2	3	4	5	6	7	8	9	
22H	40H	40H	91H	91H	D2H	D2H	42H	B1H	C1H	–	
2CH	03H	03H	03H	03H	83H	83H	A3H	13H	23H	–	
06H	0XXXXXXX						1XXXXXXX				–
30H ⁽²⁾	44H	44H	60H	60H	60H	60H	44H	60H	44H	–	

Notes

1. CLL21 = 65d, CLL22 = 128d, CLL31 = 65d, CLL32 = 128d, GAI4 = 15d, GAI3 = 15d, GAI2 = 15d; X set 0.
2. Optional: values for AD gain (+2 LSB's gain resolution) active [not active: for all modes 40H].

18 ANTI-ALIAS FILTER GRAPHS

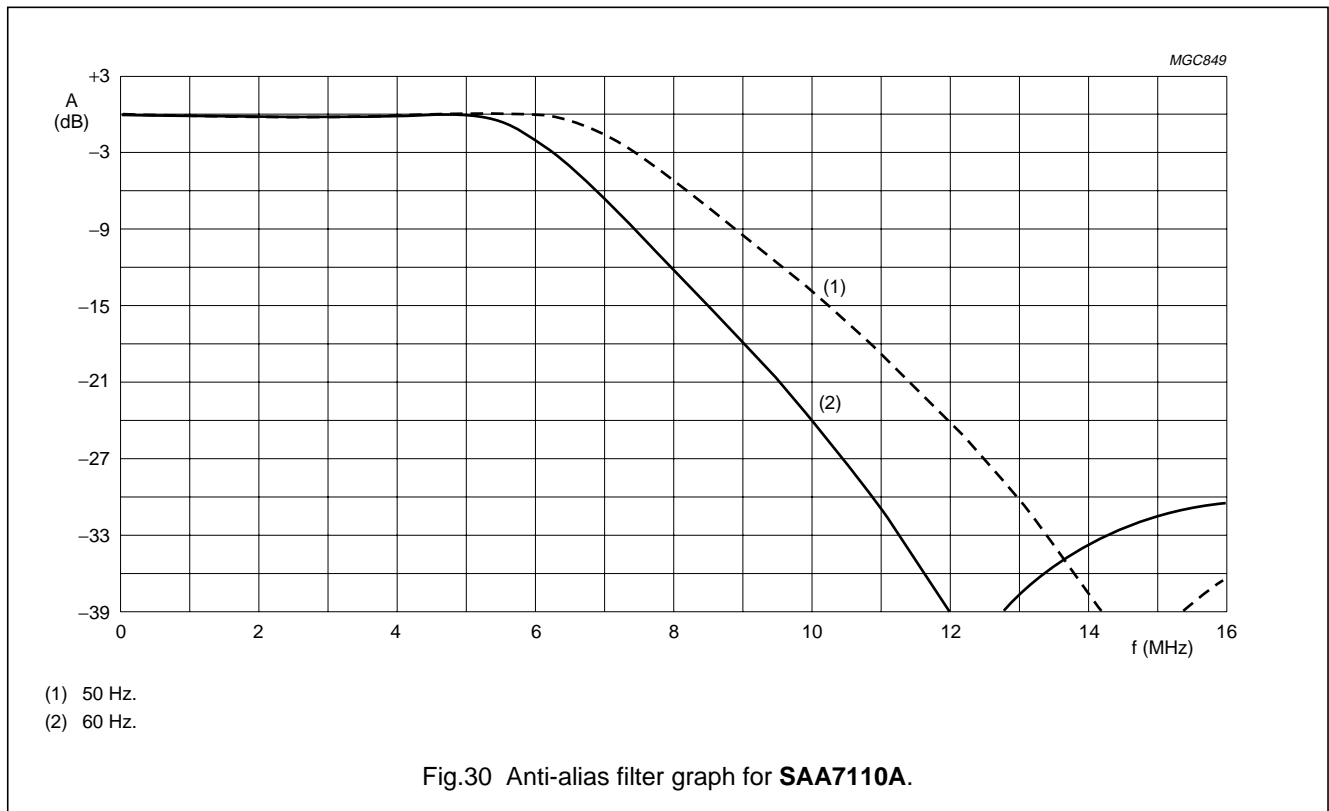

One Chip Front-end 1 (OCF1)

SAA7110; SAA7110A

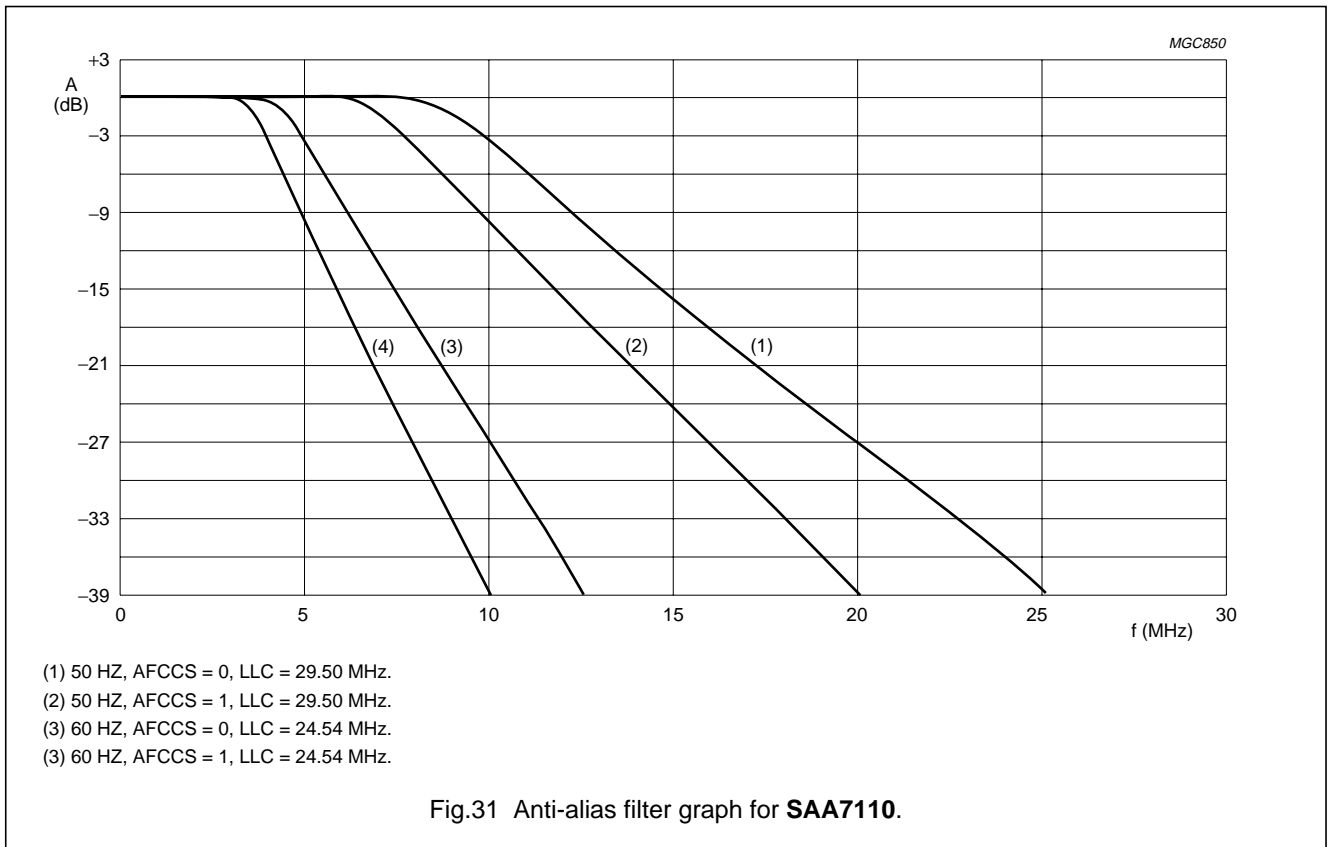

19 CORING FUNCTION

19.1 Coring function adjustment by subaddress 06H to affect band filter output adjustment

The thresholds are related to the 13-bit word width in the luminance processing part and influence the 1 to 3 LSB (Yo to Y2) with respect to the 8-bit luminance output.

Table 65 CORI control settings a, b and c of Fig.32

	CONTROL BITS	
	CORI1	CORI0
a	0	1
b	1	0
c	1	1

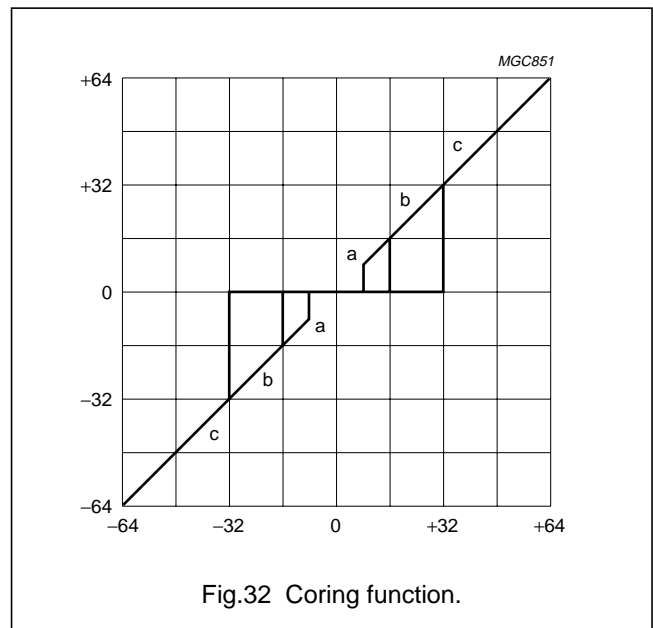

One Chip Front-end 1 (OCF1)

SAA7110; SAA7110A

20 LUMINANCE FILTER GRAPHS

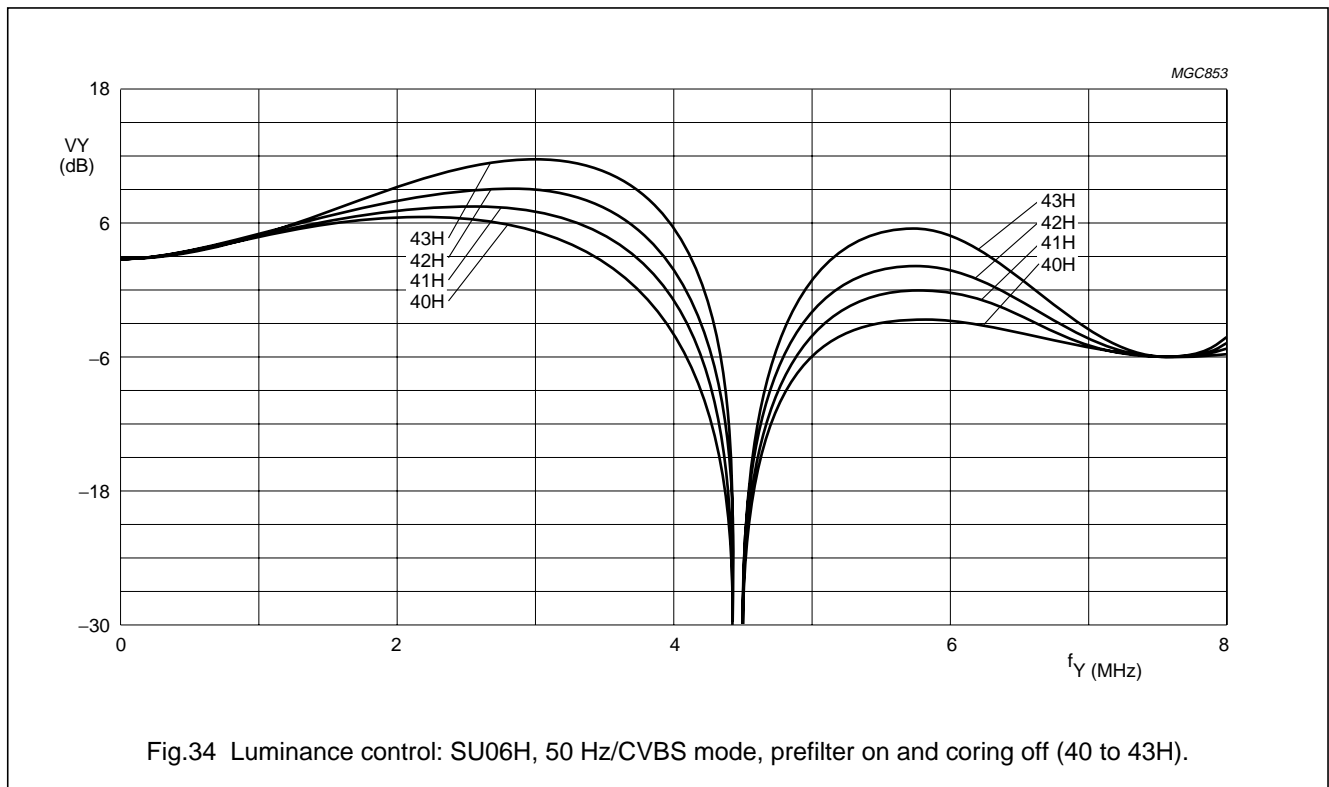
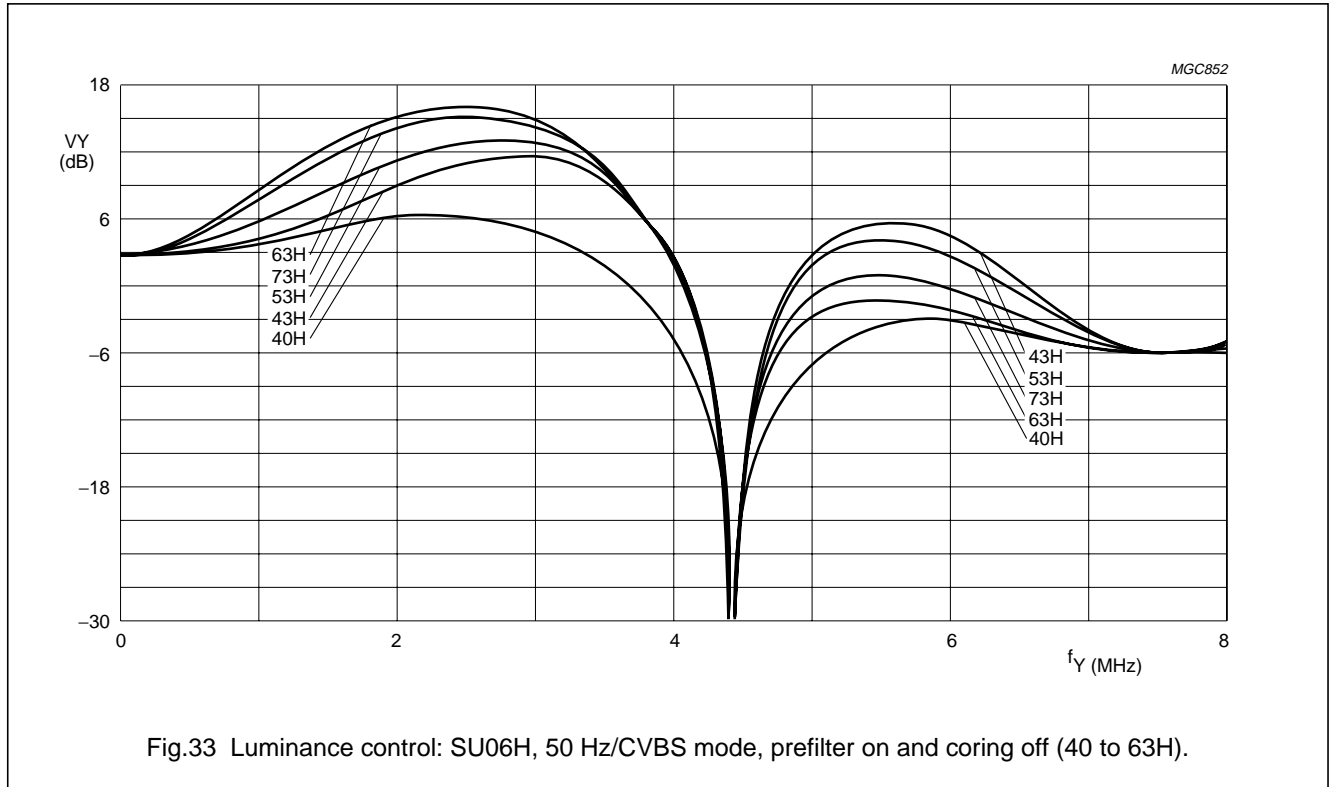

One Chip Front-end 1 (OCF1)

SAA7110; SAA7110A

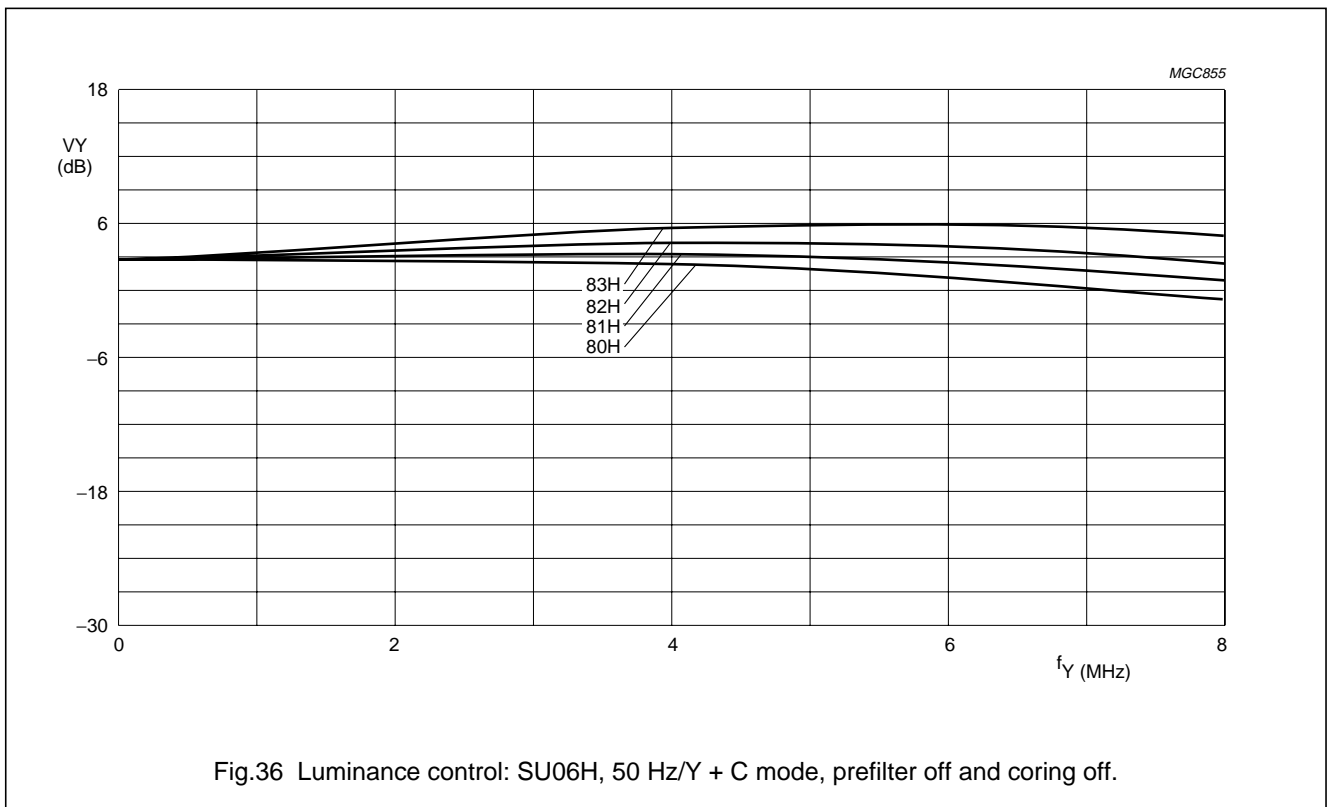
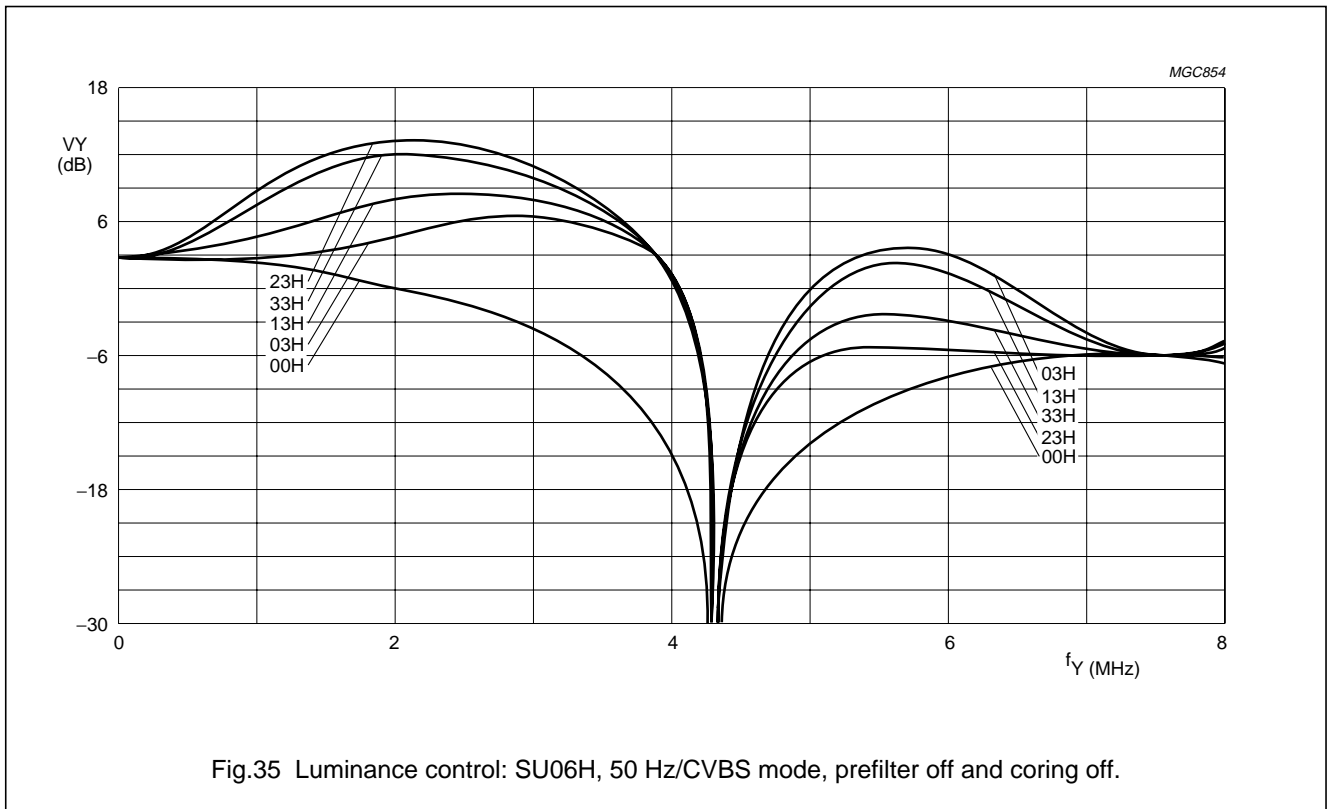

One Chip Front-end 1 (OCF1)

SAA7110; SAA7110A

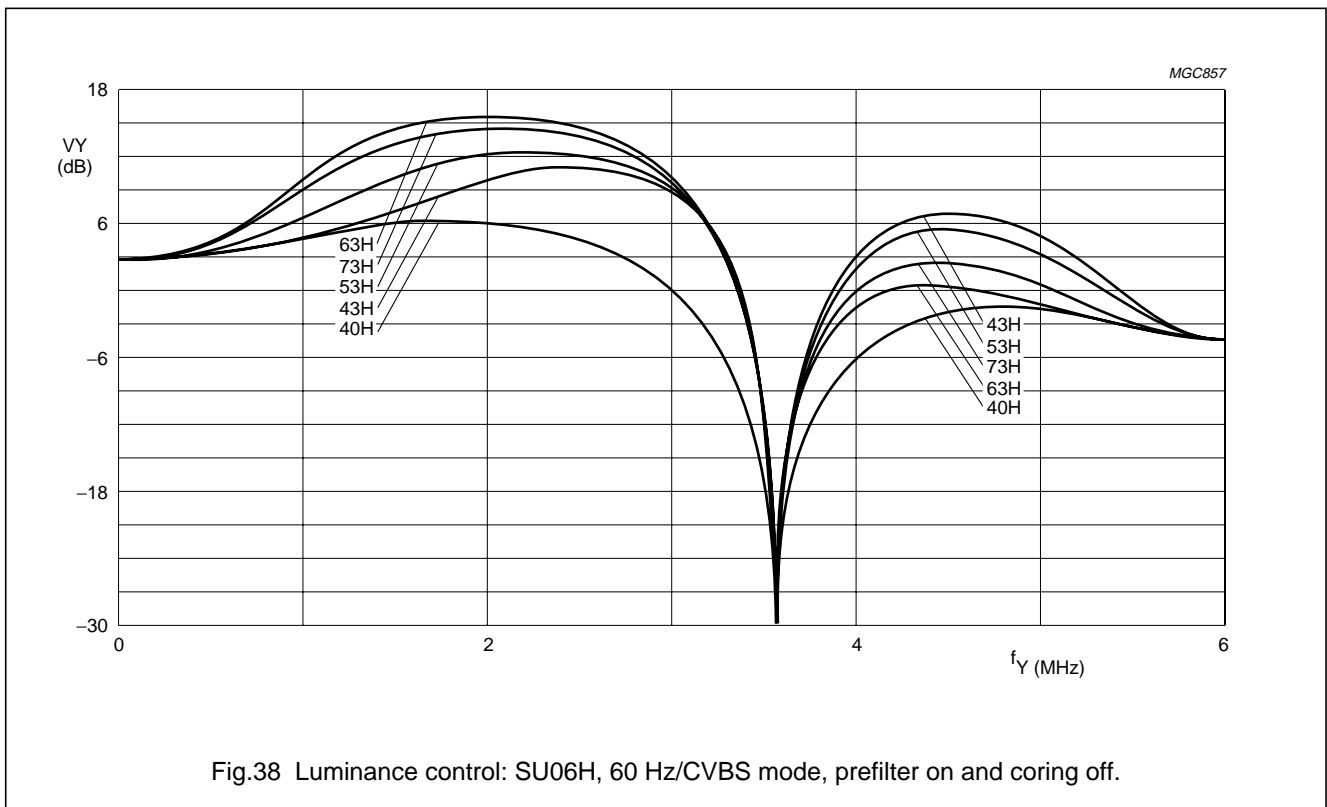
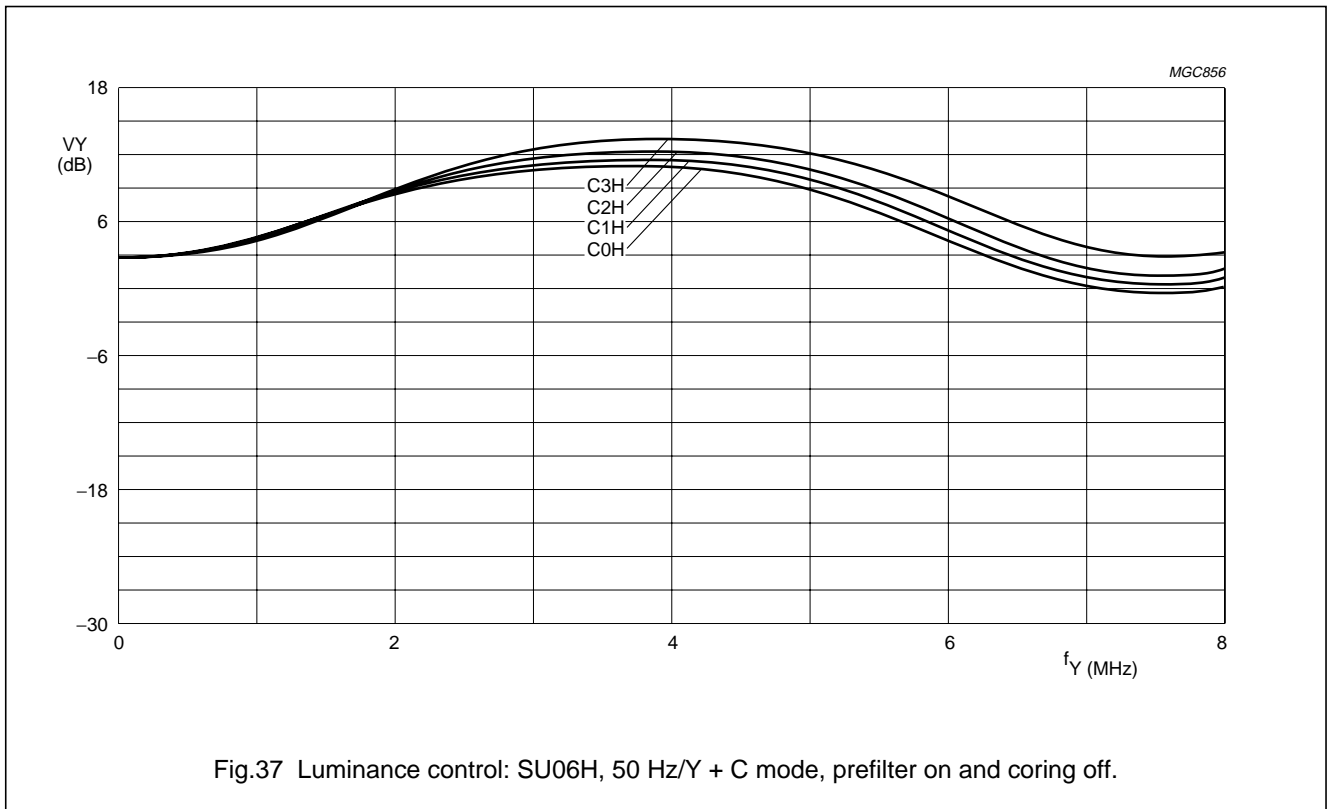

One Chip Front-end 1 (OCF1)

SAA7110; SAA7110A

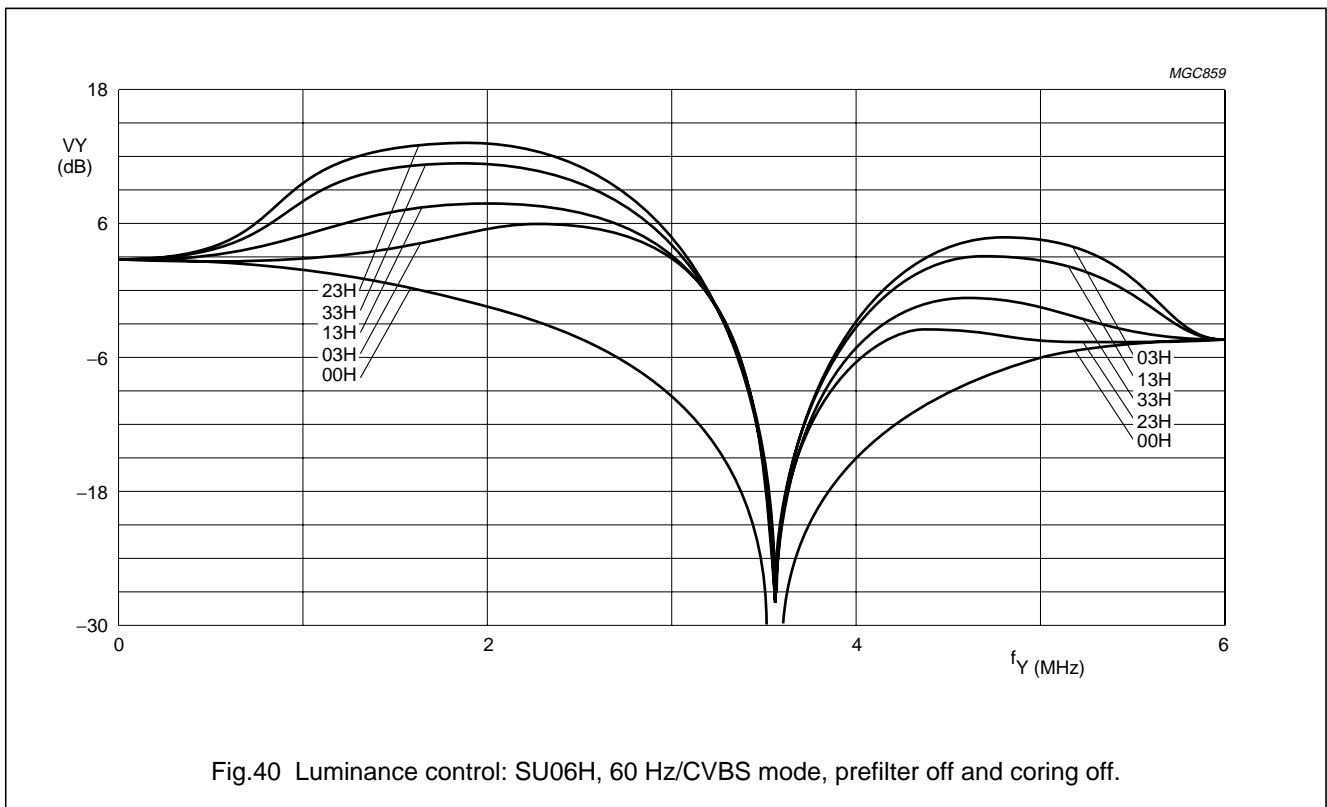
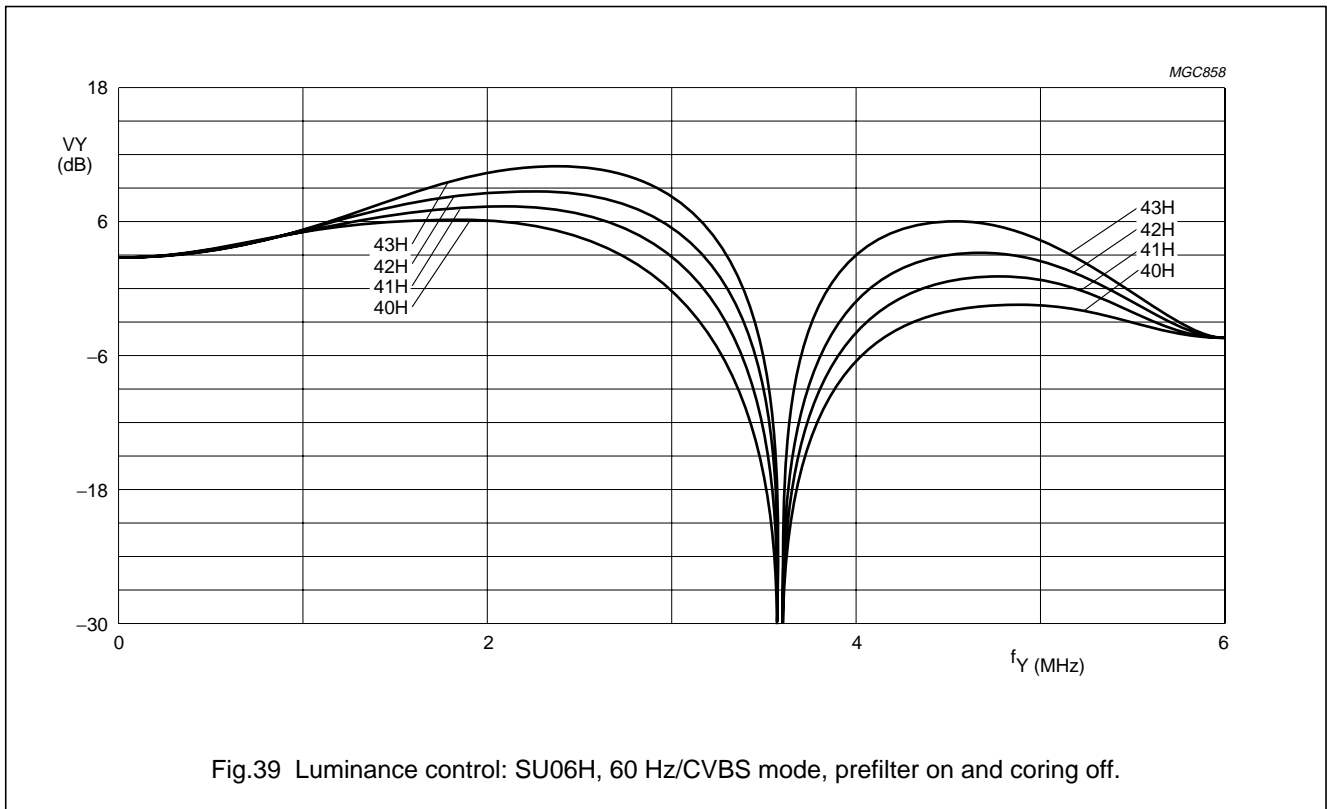

One Chip Front-end 1 (OCF1)

SAA7110; SAA7110A

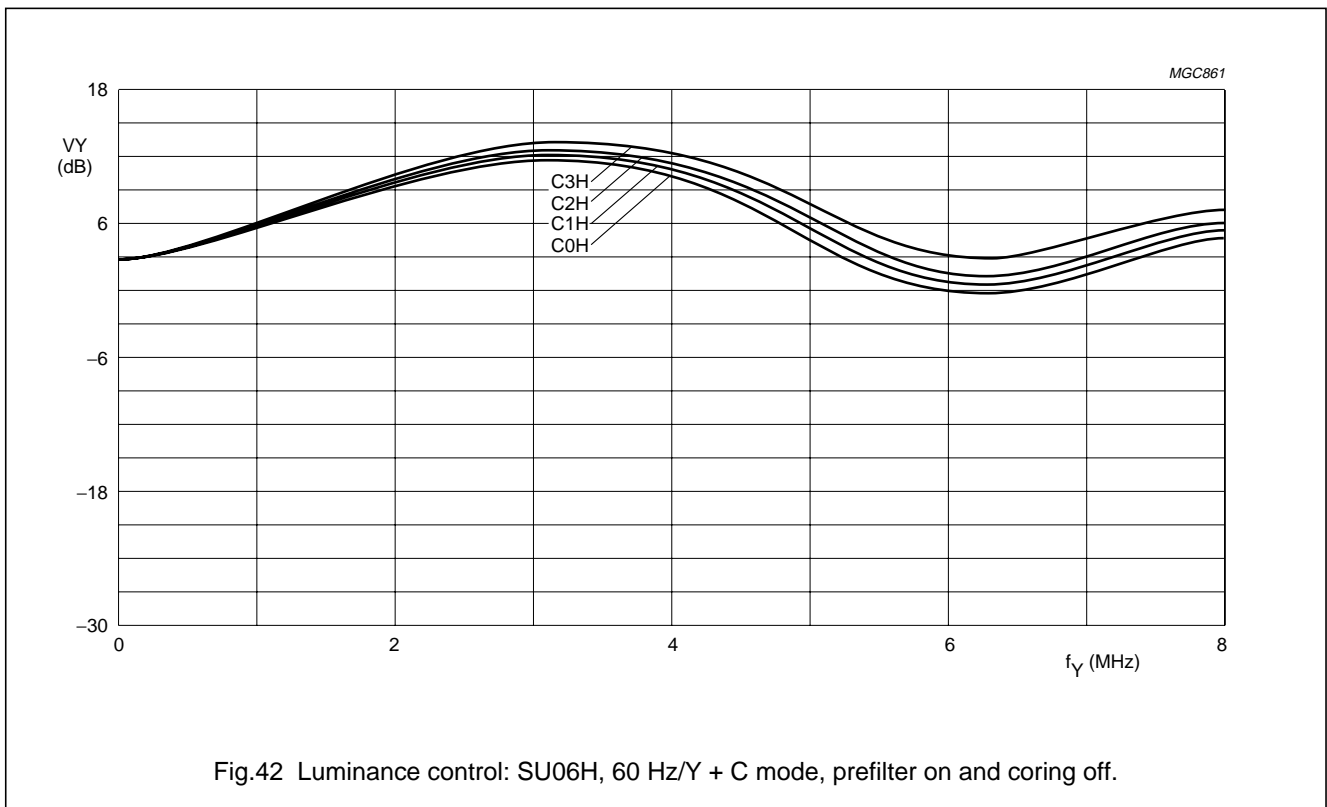
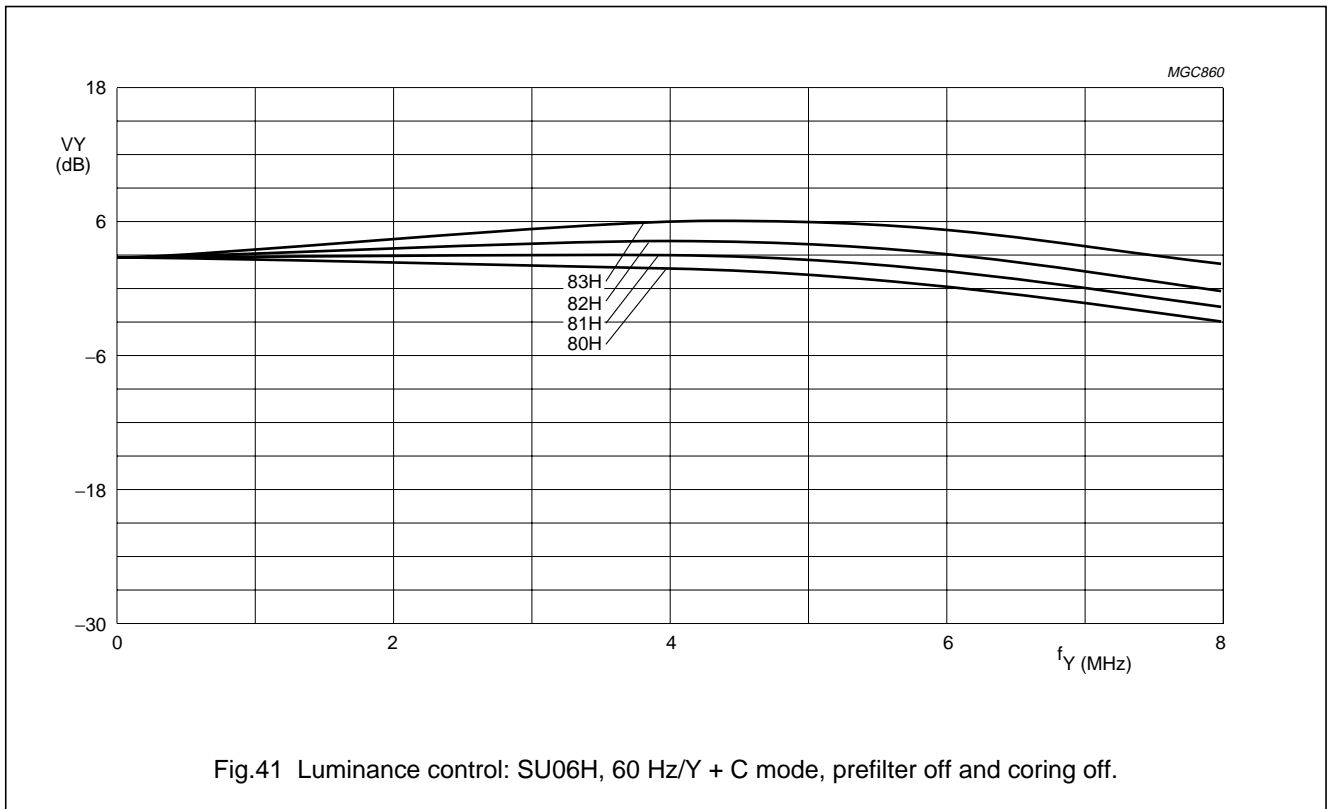

One Chip Front-end 1 (OCF1)

SAA7110; SAA7110A

21 I²C-BUS START SET-UP

The values shown in Table 66 are optimized for the EBU colour bar (100% white and 75% chrominance amplitude) signal. The decoder output signal level fulfils the CCIR 601 specification. The input of 100% colour bar level is possible, but the signal (white) peak function reduces the digital luminance output. With a different set-up it is possible to proceed 100% colour bar signal without luminance colour bar reduction. The method is to modify the AD input range for this input level by reducing the gain reference value (SBOT > 06h) and adjusting the digital Y output level with contrast and brightness control.

Table 66 I²C-bus start set-up

SU	NAME	FUNCTION	BINARY								HEX
			7	6	5	4	3	2	1	0	start
00	IDEL7 to IDEL0	increment delay	0	1	0	0	1	1	0	0	4C
01	HSYB7 to HSYB0	horizontal sync (HSY) begin 50 Hz	0	0	1	1	1	1	0	0	3C
02	HSYS7 to HSYS0	horizontal sync (HSY) stop 50 Hz	0	0	0	0	1	1	0	1	0D
03	HCLB7 to HCLB0	horizontal clamp (HCL) begin 50 Hz	1	1	1	0	1	1	1	1	EF
04	HCLS7 to HCLS0	horizontal clamp (HCL) stop 50 Hz	1	0	1	1	1	1	0	1	BD
05	HPHI7 to HPHI0	horizontal sync after PHI1 50 Hz	1	1	1	1	0	0	0	0	F0
06	BYPS, PREF, BPSS1 to BPSS0, CORI1 to CORI0, APER1 to APER0	luminance control	0	0	0	0	0	0	0	0	00
07	HUEC7 to HUEC0	hue control	0	0	0	0	0	0	0	0	00
08	CKTQ4 to CKTQ0, XXX	colour killer threshold PAL	1	1	1	1	1	X	X	X	F8
09	CKTS4 to CKTS0, XXX	colour killer threshold SECAM	1	1	1	1	1	X	X	X	F8
0A	PLSE7 to PLSE0	PAL switch sensitivity	0	1	1	0	0	0	0	0	60
0B	SESE7 to SESE0	SECAM switch sensitivity	0	1	1	0	0	0	0	0	5B
0C	COLO, LFIS1 to LFIS0, XXXXX	gain control chrominance	0	0	0	X	X	X	X	X	00
0D	VTRC, XXX, RTSE, HRMV, SSTB, SECS	standard/mode control	0	X	X	X	0	1	1	0	06
0E	HPLL, XX, OEHV, OEYC, CHRS, X, GPSW	I/O and clock control	0	X	X	1	1	0	X	0	18
0F	AUFD, FSEL, SXCR, SCEN, X, YDEL2 to YDEL0	control #1	1	0	0	1	X	0	0	0	90
10	XXXXX, HRFS, VNOI1 to VNOI0	control #2	X	X	X	X	X	0	0	0	00
11	CHCV7 to CHCV0 PAL	chrominance gain reference	0	1	0	1	1	0	0	1	59
	CHCV7 to CHCV0 NTSC		0	0	1	0	1	1	0	0	2C
12	SATN7 to SATN0	chrominance saturation	0	1	0	0	0	0	0	0	40
13	CONT7 to CONT0	luminance contrast	0	1	0	0	0	1	1	0	46
14	HS6B7 to HS6B70	horizontal sync (HSY) begin 60 Hz	0	1	0	0	0	0	1	0	42
15	HS6S7 to HS6S0	horizontal sync (HSY) stop 60 Hz	0	0	0	1	1	0	1	0	1A
16	HC6B7 to HC6B0	horizontal clamp (HCL) begin 60 Hz	1	1	1	1	1	1	1	1	FF
17	HC6S7 to HC6S0	horizontal clamp (HCL) stop 60 Hz	1	1	0	1	1	0	1	0	DA
18	HP6I7 to HP6I0	horizontal sync after PHI1 60 Hz	1	1	1	1	0	0	0	0	F0
19	BRIGI7 to BRIG0	luminance brightness	1	0	0	0	1	0	1	1	8B

One Chip Front-end 1 (OCF1)

SAA7110; SAA7110A

SU	NAME	FUNCTION	BINARY								HEX
			7	6	5	4	3	2	1	0	start
1A-1F	reserved										
20	AIND4, AIND3, AIND2, FUSE1 to FUSE0, AINS4, AINS3, AINS2	analog control #1	1	1	0	1	1	0	0	1	D9
21	VBCO, MS34, MX241 to MX240, MS24, REFS4, REFS3, REFS2	analog control #2	0	0	0	1	0	1	1	0	16
22	GACO1 to GACO0, CSEL, YSEL, MUYC, CLTS, MX341 to MX340	mixer control #1	0	1	0	0	0	0	0	0	40
23	CLL217 to CLL210	clamping level control channel 21	0	1	0	0	0	0	0	1	41
24	CLL227 to CLL220	clamping level control channel 22	1	0	0	0	0	0	0	0	80
25	CLL317 to CLL310	clamping level control channel 31	0	1	0	0	0	0	0	1	41
26	CLL327 to CLL320	clamping level control channel 32	1	0	0	0	0	0	0	0	80
27	HOLD, GASL, GAI25 to GAI20	gain control analog #1	0	1	0	0	1	1	1	1	4F
28	WIPE7 to WIPE0	white peak control	1	1	1	1	1	1	1	0	FE
29	SBOT7 to SBOT0	sync bottom control	0	0	0	0	0	0	0	1	01
2A	IWIP1 to IWIP0, GAI35 to GAI30	gain control analog #2	1	1	0	0	1	1	1	1	CF
2B	IGAI1 to IGAI0, GAI45 to GAI40	gain control analog #3	0	0	0	0	1	1	1	1	0F
2C	CLS4, X, CLS3, CLS2, TWO3, TWO2	mixer control #2	0	X	0	0	X	X	1	1	03
2D	IVAL7 to IVAL0	integration value gain	0	0	0	0	0	0	0	1	01
2E	VBPS7 to VBPS0; 50 Hz	vertical blanking pulse SET	1	0	0	1	1	0	1	0	9A
	VBPS7 to VBPS0; 60 Hz		1	0	0	0	0	0	0	1	81
2F	VBPR7 to VBPR0; 50 Hz	vertical blanking pulse RESET	0	0	0	0	0	0	1	1	03
	VBPR7 to VBPR0; 60 Hz		0	0	0	0	0	0	1	1	
30	X, WISL, GAS3, GAD31 to GAD30, GAS2, GAD21 to GAD20	ADCs gain control	X	1	0	0	0	0	0	0	44
31	AOSL1 to AOSL0, WIRS, WRSE, SQPB, X, VBLKA, PULIO	mixer control #3	0	1	1	1	0	X*	0	1	71
32	WVAL7 to WVAL0	integration value white peak	0	0	0	0	0	0	1	0	02
33	OFTS, X, CHSB, X, CAD3, CAD2, XX	mixer control #4	1	X	0	X	1	1	X	X	8C
34	MUD2, MUD1, GUDL5 to GUDL0	gain update level	0	0	0	0	0	0	1	1	03

21.1 Remarks to Table 66

Values recommended for a CVBS (PAL or NTSC) signal, input AI21 via A/D channel 2 (MODE 0), and 4 : 2 : 2 CCIR output signal level; all X values must be set LOW, X* value is don't care; HPHI and HP6I are application dependent.

One Chip Front-end 1 (OCF1)

SAA7110; SAA7110A

22 APPLICATION INFORMATION

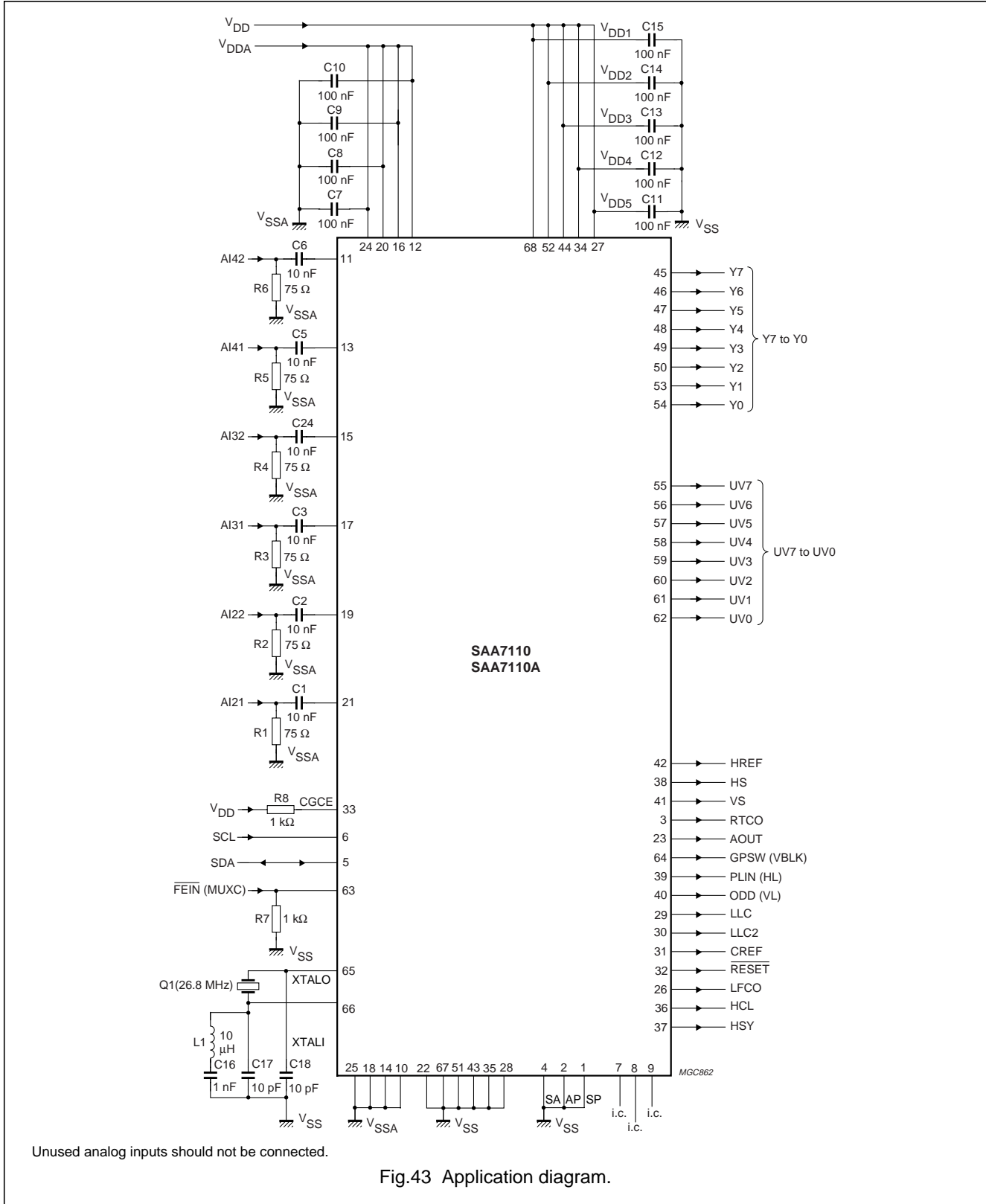

One Chip Front-end 1 (OCF1)

SAA7110; SAA7110A

23 START-UP, SOURCE SELECT AND STANDARD DETECTION FLOW EXAMPLE

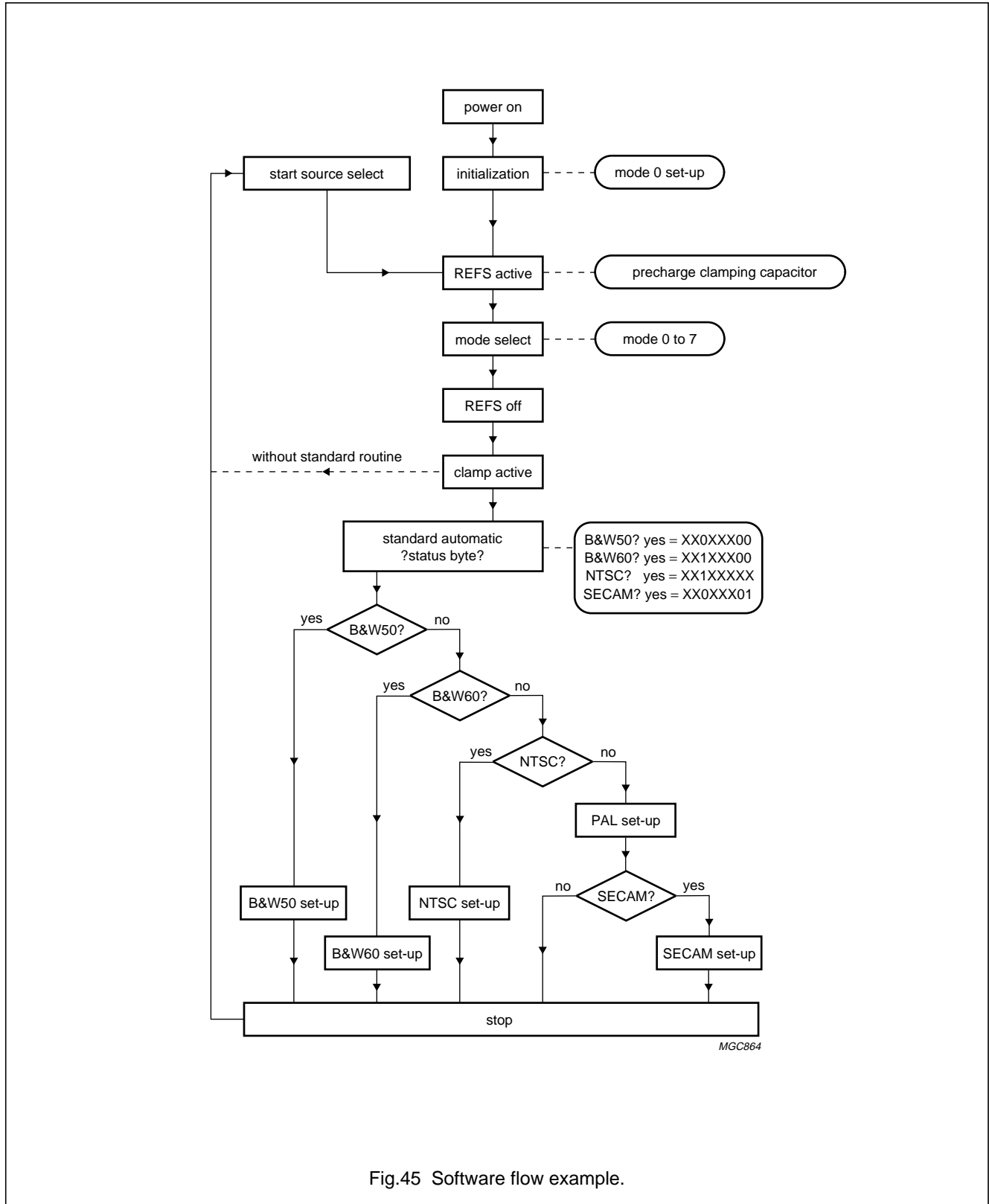

Fig.45 Software flow example.

One Chip Front-end 1 (OCF1)

SAA7110; SAA7110A

23.1 CODE 0 STARTUP and STANDARD Procedure

```

SLAVE 9C          !OCF1 NTSC-setup
SUB 00 WRITE
4C 3C 0D EF BD F0 00 00
F8 F8 60 60 00 06 18 90
00 2C 40 46 42 1A FF DA
F0 8B 00 00 00 00 00 00
D9 17 40 41 80 41 80 4F
FE 01 CF 0F 03 01 81 03
44 75 01 8C 03
SUB 21 WRITE 16   !REFS OFF CLAMP AKTIV
READ 1           !Status?
#STANDARD
IF 1 @XX0XXX00   !NO COLOR
THEN GOTO BW_50Hz
ENDIF
IF 1 @XX1XXX00   !NO COLOR
THEN GOTO BW_60Hz
ENDIF
SUB 06 WRITE 00
ENDIF
IF 1 @XX1XXXXX   !60Hz
THEN GOTO NTSC
ENDIF
IF 1 @XX0XXXXX   !50Hz
THEN GOTO PAL
ENDIF
#BW_50Hz
PRINT "BLACK&WHITE"
SUB 06 WRITE 80
SUB 2E WRITE 9A   !VBPS
GOTO STOP
#BW_60Hz
PRINT "BLACK&WHITE"
SUB 06 WRITE 80
SUB 2E WRITE 81   !VBPS
GOTO STOP
#NTSC
SUB 0D WRITE 06   !SECS -> 0
SUB 11 WRITE 2C   !CHCV
SUB 2E WRITE 81   !VBPS
PRINT "NTSC"
GOTO STOP
#PAL
SUB 0D WRITE 06   !SECS -> 0
SUB 11 WRITE 59   !CHCV
SUB 2E WRITE 9A   !VBPS
PAUSE %150        !150ms
IF 1 @XX0XXX01
THEN GOTO SECAM
ELSE PRINT "PAL"
GOTO STOP

```

```

#SECAM
SUB 0D WRITE 07   !SECS -> 1
PRINT "SECAM"
GOTO STOP
#STOP

```

23.2 MODE 0 Source Select Procedure

```

SLAVE 9C          !OCF1
SUB 06 WRITE 00   !CVBS MODE 0
SUB 20 WRITE D9   !AI21 ACTIVE
SUB 21 WRITE 17   !REFS ON
SUB 22 WRITE 40   !AD2->LUMA and CHROMA
SUB 2C WRITE 03   !CLAMP SELECT
SUB 30 WRITE 44   !Gain AD2 active
SUB 31 WRITE 75   !AOSL -> 01b
SUB 21 WRITE 16   !REFS OFF CLAMP AKTIV

```

23.3 MODE 1 Source Select Procedure

```

SLAVE 9C          !OCF1
SUB 06 WRITE 00   !CVBS MODE 1
SUB 20 WRITE D8   !AI22 ACTIVE
SUB 21 WRITE 17   !REFS ON
SUB 22 WRITE 40   !AD2->LUMA and CHROMA
SUB 2C WRITE 03   !CLAMP SELECT
SUB 30 WRITE 44   !Gain AD2 active
SUB 31 WRITE 75   !AOSL -> 01b
SUB 21 WRITE 16   !REFS OFF CLAMP AKTIV

```

23.4 MODE 2 Source Select Procedure

```

SLAVE 9C          !OCF1
SUB 06 WRITE 00   !CVBS MODE 2
SUB 20 WRITE BA   !AI31 ACTIVE
SUB 21 WRITE 07   !REFS ON
SUB 22 WRITE 91   !AD3->LUMA and CHROMA
SUB 2C WRITE 03   !CLAMP SELECT
SUB 30 WRITE 60   !Gain AD3 active
SUB 31 WRITE B5   !AOSL -> 10b
SUB 21 WRITE 05   !REFS OFF CLAMP AKTIV

```

23.5 MODE 3 Source Select Procedure

```

SLAVE 9C          !OCF1
SUB 06 WRITE 00   !CVBS MODE 3
SUB 20 WRITE B8   !AI32 ACTIVE
SUB 21 WRITE 07   !REFS ON
SUB 22 WRITE 91   !AD3->LUMA and CHROMA
SUB 2C WRITE 03   !CLAMP SELECT
SUB 30 WRITE 60   !Gain AD3 active
SUB 31 WRITE B5   !AOSL -> 10b
SUB 21 WRITE 05   !REFS OFF CLAMP AKTIV

```

One Chip Front-end 1 (OCF1)
SAA7110; SAA7110A

23.6 MODE 4 Source Select Procedure

```

SLAVE 9C          !OCF1
SUB 06 WRITE 00   !CVBS MODE 4
SUB 20 WRITE 7C   !AI41 ACTIVE
SUB 21 WRITE 07   !REFS ON
SUB 22 WRITE D2   !AD3->LUMA and CHROMA
SUB 2C WRITE 83   !CLAMP SELECT
SUB 30 WRITE 60   !Gain AD3 active
SUB 31 WRITE B5   !AOSL -> 10b
SUB 21 WRITE 03   !REFS OFF CLAMP AKTIV

```

```

SUB 2C WRITE 23   !CLAMP SELECT
SUB 30 WRITE 44   !Gain AD2 active
SUB 31 WRITE 75   !AOSL -> 01
SUB 21 WRITE 21   !REFS OFF CLAMP AKTIV

```

23.7 MODE 5 Source Select Procedure

```

SLAVE 9C          !OCF1
SUB 06 WRITE 00   !CVBS MODE 5
SUB 20 WRITE 78   !AI41 ACTIVE
SUB 21 WRITE 07   !REFS ON
SUB 22 WRITE D2   !AD3->LUMA and CHROMA
SUB 2C WRITE 83   !CLAMP SELECT
SUB 30 WRITE 60   !Gain AD3 active
SUB 31 WRITE B5   !AOSL -> 10b
SUB 21 WRITE 03   !REFS OFF CLAMP AKTIV

```

23.8 MODE 6 Source Select Procedure

```

SLAVE 9C          !OCF1
SUB 06 WRITE 80   !Y+C MODE 6
SUB 20 WRITE 59   !AI21=Y, AI42=C
SUB 21 WRITE 17   !REFS ON
SUB 22 WRITE 42   !AD2->LUMA, AD3->CHR
SUB 2C WRITE A3   !CLAMP SELECT
SUB 30 WRITE 44   !Gain AD2 active
SUB 31 WRITE 75   !AOSL -> 01
SUB 21 WRITE 12   !REFS OFF CLAMP AKTIV

```

23.9 MODE 7 Source Select Procedure

```

SLAVE 9C          !OCF1
SUB 06 WRITE 80   !Y+C MODE 7
SUB 20 WRITE 9A   !AI31=Y, AI22=C
SUB 21 WRITE 17   !REFS ON
SUB 22 WRITE B1   !AD3->LUMA, AD2->CHR
SUB 2C WRITE 13   !CLAMP SELECT
SUB 30 WRITE 60   !Gain AD3 active
SUB 31 WRITE B5   !AOSL -> 10b
SUB 21 WRITE 14   !REFS OFF CLAMP AKTIV

```

23.10 MODE 8 Source Select Procedure

```

SLAVE 9C          !OCF1
SUB 06 WRITE 80   !Y+C MODE 8
SUB 20 WRITE 3C   !AI41=Y, AI32=C
SUB 21 WRITE 27   !REFS ON
SUB 22 WRITE C1   !AD2->LUMA, AD3->CHR

```

One Chip Front-end 1 (OCF1)

SAA7110; SAA7110A

24 PACKAGE OUTLINE

PLCC68: plastic leaded chip carrier; 68 leads

SOT188-2

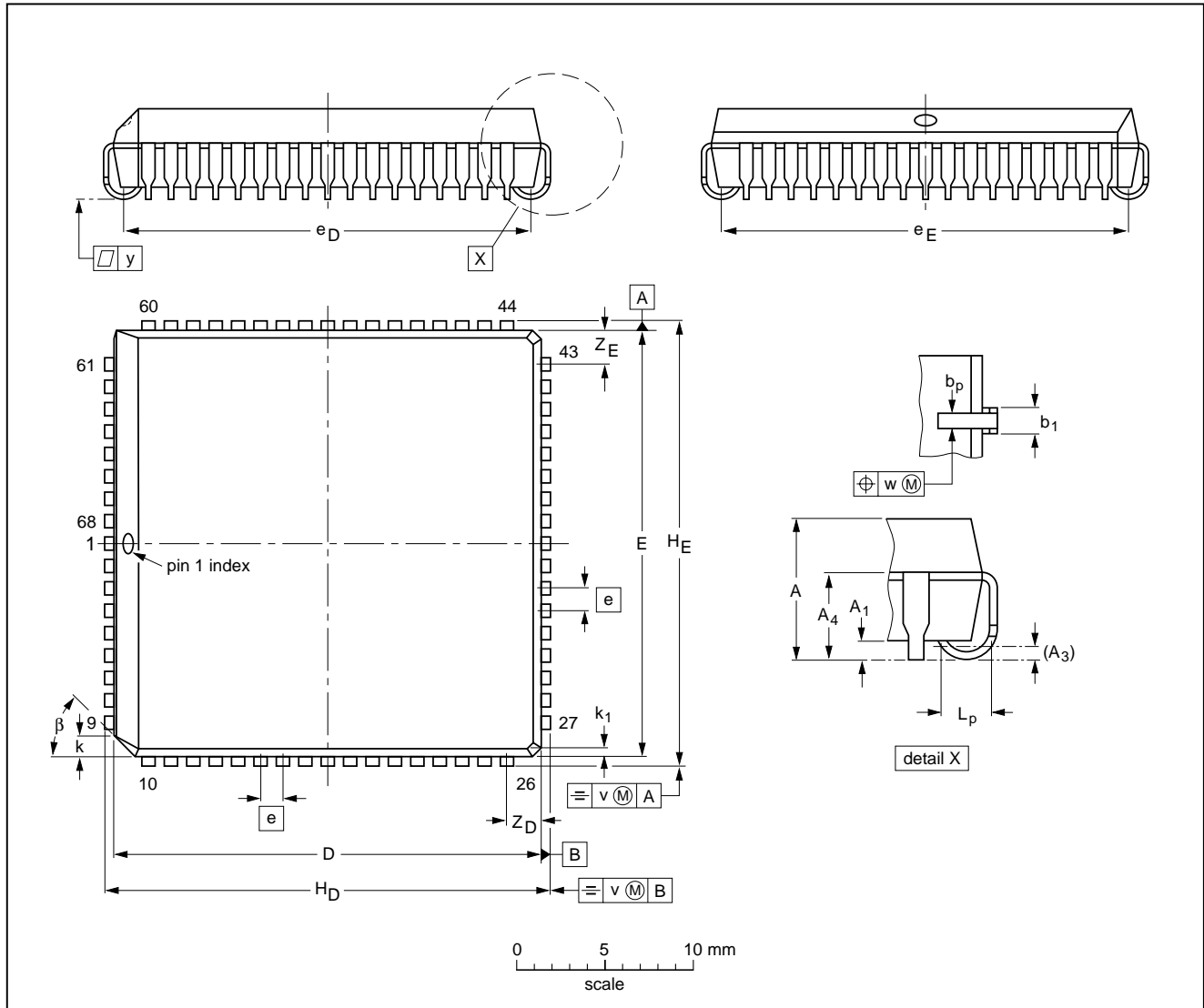

DIMENSIONS (millimetre dimensions are derived from the original inch dimensions)

UNIT	A	A ₁ min.	A ₃	A ₄ max.	b _p	b ₁	D ⁽¹⁾	E ⁽¹⁾	e	e _D	e _E	H _D	H _E	k	k ₁ max.	L _p	v	w	y	Z _D ⁽¹⁾ max.	Z _E ⁽¹⁾ max.	β
mm	4.57 4.19	0.51	0.25	3.30	0.53 0.33	0.81 0.66	24.33 24.13	24.33 24.13	1.27	23.62 22.61	23.62 22.61	25.27 25.02	25.27 25.02	1.22 1.07	0.51	1.44 1.02	0.18	0.18	0.10	2.16	2.16	45°
inches	0.180 0.165	0.020	0.01	0.13	0.021 0.013	0.032 0.026	0.958 0.950	0.958 0.950	0.05	0.930 0.890	0.930 0.890	0.995 0.985	0.995 0.985	0.048 0.042	0.020	0.057 0.040	0.007	0.007	0.004	0.085	0.085	

Note
1. Plastic or metal protrusions of 0.01 inches maximum per side are not included.

OUTLINE VERSION	REFERENCES				EUROPEAN PROJECTION	ISSUE DATE
	IEC	JEDEC	EIAJ			
SOT188-2	112E10	MO-047AC				92-11-17 95-03-11

One Chip Front-end 1 (OCF1)

SAA7110; SAA7110A

25 SOLDERING

25.1 Introduction

There is no soldering method that is ideal for all IC packages. Wave soldering is often preferred when through-hole and surface mounted components are mixed on one printed-circuit board. However, wave soldering is not always suitable for surface mounted ICs, or for printed-circuits with high population densities. In these situations reflow soldering is often used.

This text gives a very brief insight to a complex technology. A more in-depth account of soldering ICs can be found in our *"IC Package Databook"* (order code 9398 652 90011).

25.2 Reflow soldering

Reflow soldering techniques are suitable for all PLCC packages.

The choice of heating method may be influenced by larger PLCC packages (44 leads, or more). If infrared or vapour phase heating is used and the large packages are not absolutely dry (less than 0.1% moisture content by weight), vaporization of the small amount of moisture in them can cause cracking of the plastic body. For more information, refer to the Drypack chapter in our *"Quality Reference Handbook"* (order code 9398 510 63011).

Reflow soldering requires solder paste (a suspension of fine solder particles, flux and binding agent) to be applied to the printed-circuit board by screen printing, stencilling or pressure-syringe dispensing before package placement.

Several techniques exist for reflowing; for example, thermal conduction by heated belt. Dwell times vary between 50 and 300 seconds depending on heating method. Typical reflow temperatures range from 215 to 250 °C.

Preheating is necessary to dry the paste and evaporate the binding agent. Preheating duration: 45 minutes at 45 °C.

25.3 Wave soldering

Wave soldering techniques can be used for all PLCC packages if the following conditions are observed:

- A double-wave (a turbulent wave with high upward pressure followed by a smooth laminar wave) soldering technique should be used.
- The longitudinal axis of the package footprint must be parallel to the solder flow.
- The package footprint must incorporate solder thieves at the downstream corners.

During placement and before soldering, the package must be fixed with a droplet of adhesive. The adhesive can be applied by screen printing, pin transfer or syringe dispensing. The package can be soldered after the adhesive is cured.

Maximum permissible solder temperature is 260 °C, and maximum duration of package immersion in solder is 10 seconds, if cooled to less than 150 °C within 6 seconds. Typical dwell time is 4 seconds at 250 °C.

A mildly-activated flux will eliminate the need for removal of corrosive residues in most applications.

25.4 Repairing soldered joints

Fix the component by first soldering two diagonally-opposite end leads. Use only a low voltage soldering iron (less than 24 V) applied to the flat part of the lead. Contact time must be limited to 10 seconds at up to 300 °C. When using a dedicated tool, all other leads can be soldered in one operation within 2 to 5 seconds between 270 and 320 °C.

One Chip Front-end 1 (OCF1)

SAA7110; SAA7110A

26 DEFINITIONS

Data sheet status	
Objective specification	This data sheet contains target or goal specifications for product development.
Preliminary specification	This data sheet contains preliminary data; supplementary data may be published later.
Product specification	This data sheet contains final product specifications.
Limiting values	
Limiting values given are in accordance with the Absolute Maximum Rating System (IEC 134). Stress above one or more of the limiting values may cause permanent damage to the device. These are stress ratings only and operation of the device at these or at any other conditions above those given in the Characteristics sections of the specification is not implied. Exposure to limiting values for extended periods may affect device reliability.	
Application information	
Where application information is given, it is advisory and does not form part of the specification.	

27 LIFE SUPPORT APPLICATIONS

These products are not designed for use in life support appliances, devices, or systems where malfunction of these products can reasonably be expected to result in personal injury. Philips customers using or selling these products for use in such applications do so at their own risk and agree to fully indemnify Philips for any damages resulting from such improper use or sale.

28 PURCHASE OF PHILIPS I²C COMPONENTS



Purchase of Philips I²C components conveys a license under the Philips' I²C patent to use the components in the I²C system provided the system conforms to the I²C specification defined by Philips. This specification can be ordered using the code 9398 393 40011.

One Chip Front-end 1 (OCF1)

SAA7110; SAA7110A

NOTES

Philips Semiconductors – a worldwide company

Argentina: IEROD, Av. Juramento 1992 - 14.b, (1428)
BUENOS AIRES, Tel. (541)786 7633, Fax. (541)786 9367

Australia: 34 Waterloo Road, NORTH RYDE, NSW 2113,
Tel. (02)805 4455, Fax. (02)805 4466

Austria: Triester Str. 64, A-1101 WIEN, P.O. Box 213,
Tel. (01)60 101-1236, Fax. (01)60 101-1211

Belgium: Postbus 90050, 5600 PB EINDHOVEN, The Netherlands,
Tel. (31)40-2783749, Fax. (31)40-2788399

Brazil: Rua do Rocio 220 - 5th floor, Suite 51,
CEP: 04552-903-SÃO PAULO-SP, Brazil.
P.O. Box 7383 (01064-970),
Tel. (011)821-2333, Fax. (011)829-1849

Canada: PHILIPS SEMICONDUCTORS/COMPONENTS:
Tel. (800) 234-7381, Fax. (708) 296-8556

Chile: Av. Santa Maria 0760, SANTIAGO,
Tel. (02)773 816, Fax. (02)777 6730

China/Hong Kong: 501 Hong Kong Industrial Technology Centre,
72 Tat Chee Avenue, Kowloon Tong, HONG KONG,
Tel. (852)2319 7888, Fax. (852)2319 7700

Colombia: IPRELENZO LTDA, Carrera 21 No. 56-17,
77621 BOGOTA, Tel. (571)249 7624/(571)217 4609,
Fax. (571)217 4549

Denmark: Prags Boulevard 80, PB 1919, DK-2300
COPENHAGEN S, Tel. (032)88 2636, Fax. (031)57 1949

Finland: Sinikalliontie 3, FIN-02630 ESPOO,
Tel. (358)0-615 800, Fax. (358)0-61580 920

France: 4 Rue du Port-aux-Vins, BP317,
92156 SURESNES Cedex,
Tel. (01)4099 6161, Fax. (01)4099 6427

Germany: P.O. Box 10 63 23, 20043 HAMBURG,
Tel. (040)3296-0, Fax. (040)3296 213.

Greece: No. 15, 25th March Street, GR 17778 TAVROS,
Tel. (01)4894 339/4894 911, Fax. (01)4814 240

India: Philips INDIA Ltd, Shivsagar Estate, A Block,
Dr. Annie Besant Rd. Worli, Bombay 400 018
Tel. (022)4938 541, Fax. (022)4938 722

Indonesia: Philips House, Jalan H.R. Rasuna Said Kav. 3-4,
P.O. Box 4252, JAKARTA 12950,
Tel. (021)5201 122, Fax. (021)5205 189

Ireland: Newstead, Clonskeagh, DUBLIN 14,
Tel. (01)7640 000, Fax. (01)7640 200

Italy: PHILIPS SEMICONDUCTORS S.r.l.,
Piazza IV Novembre 3, 20124 MILANO,
Tel. (0039)2 6752 2531, Fax. (0039)2 6752 2557

Japan: Philips Bldg 13-37, Kohnan2-chome, Minato-ku, TOKYO 108,
Tel. (03)3740 5130, Fax. (03)3740 5077

Korea: Philips House, 260-199 Itaewon-dong,
Yongsan-ku, SEOUL, Tel. (02)709-1412, Fax. (02)709-1415

Malaysia: No. 76 Jalan Universiti, 46200 PETALING JAYA,
SELANGOR, Tel. (03)750 5214, Fax. (03)757 4880

Mexico: 5900 Gateway East, Suite 200, EL PASO, TX 79905,
Tel. 9-5(800)234-7381, Fax. (708)296-8556

Netherlands: Postbus 90050, 5600 PB EINDHOVEN, Bldg. VB,
Tel. (040)2783749, Fax. (040)2788399

New Zealand: 2 Wagener Place, C.P.O. Box 1041, AUCKLAND,
Tel. (09)849-4160, Fax. (09)849-7811

Norway: Box 1, Manglerud 0612, OSLO,
Tel. (022)74 8000, Fax. (022)74 8341

Pakistan: Philips Electrical Industries of Pakistan Ltd.,
Exchange Bldg. ST-2/A, Block 9, KDA Scheme 5, Clifton,
KARACHI 75600, Tel. (021)587 4641-49,
Fax. (021)577035/5874546

Philippines: PHILIPS SEMICONDUCTORS PHILIPPINES Inc,
106 Valero St. Salcedo Village, P.O. Box 2108 MCC, MAKATI,
Metro MANILA, Tel. (63) 2 816 6380, Fax. (63) 2 817 3474

Portugal: PHILIPS PORTUGUESA, S.A.,
Rua dr. António Loureiro Borges 5, Arquiparque - Miraflores,
Apartado 300, 2795 LINDA-A-VELHA,
Tel. (01)4163160/4163333, Fax. (01)4163174/4163366

Singapore: Lorong 1, Toa Payoh, SINGAPORE 1231,
Tel. (65)350 2000, Fax. (65)251 6500

South Africa: S.A. PHILIPS Pty Ltd.,
195-215 Main Road Martindale, 2092 JOHANNESBURG,
P.O. Box 7430, Johannesburg 2000,
Tel. (011)470-5911, Fax. (011)470-5494

Spain: Balmes 22, 08007 BARCELONA,
Tel. (03)301 6312, Fax. (03)301 42 43

Sweden: Kottbygatan 7, Akalla. S-164 85 STOCKHOLM,
Tel. (0)8-632 2000, Fax. (0)8-632 2745

Switzerland: Allmendstrasse 140, CH-8027 ZÜRICH,
Tel. (01)488 2211, Fax. (01)481 77 30

Taiwan: PHILIPS TAIWAN Ltd., 23-30F, 66, Chung Hsiao West
Road, Sec. 1, Taipei, Taiwan ROC, P.O. Box 22978,
TAIPEI 100, Tel. (886) 2 382 4443, Fax. (886) 2 382 4444

Thailand: PHILIPS ELECTRONICS (THAILAND) Ltd.,
209/2 Sanpavuth-Bangna Road Prakanong,
Bangkok 10260, THAILAND,
Tel. (66) 2 745-4090, Fax. (66) 2 398-0793

Turkey: Talatpasa Cad. No. 5, 80640 GÜLTEPE/ISTANBUL,
Tel. (0212)279 27 70, Fax. (0212)282 67 07

United Kingdom: Philips Semiconductors LTD.,
276 Bath Road, Hayes, MIDDLESEX UB3 5BX,
Tel. (0181)730-5000, Fax. (0181)754-8421

United States: 811 East Arques Avenue, SUNNYVALE,
CA 94088-3409, Tel. (800)234-7381, Fax. (708)296-8556

Uruguay: Coronel Mora 433, MONTEVIDEO,
Tel. (02)70-4044, Fax. (02)92 0601

Internet: <http://www.semiconductors.philips.com/ps/>

For all other countries apply to: Philips Semiconductors,
International Marketing and Sales, Building BE-p,
P.O. Box 218, 5600 MD EINDHOVEN, The Netherlands,
Telex 35000 phtncl, Fax. +31-40-2724825

SCD44

© Philips Electronics N.V. 1995

All rights are reserved. Reproduction in whole or in part is prohibited without the prior written consent of the copyright owner.

The information presented in this document does not form part of any quotation or contract, is believed to be accurate and reliable and may be changed without notice. No liability will be accepted by the publisher for any consequence of its use. Publication thereof does not convey nor imply any license under patent- or other industrial or intellectual property rights.

Printed in The Netherlands

483061/1500/01/pp76
Document order number:

Date of release: 1995 Oct 18
9397 750 00368